



# E51/E53/E55

AC/DC FILM CAPACITORS



HIGH VOLTAGES, HEAVY CURRENTS, AND LOW INDUCTANCE

**ELECTRONICON**<sup>®</sup>  
always in charge

Choose the best capacitor  
for any of your power electronics applications:

AC and DC capacitors with integrated safety mechanism  
E62 AC/DC E62-3ph AC Filter E63 DC

Low-inductance capacitors  
E50 PK16™ DC E53 AC/DC E61 DC

Low-inductance High-voltage capacitors  
E51

AC and DC capacitors with large capacitance  
E56 DC E59 AC/DC E70 AC E50.U SR17™ DC

CAPACITORS

**ELECTRONICON®**

*always in charge*

# **E51/E53/E55 AC/DC**

## **LOW-INDUCTANCE FILM CAPACITORS**

### **NIEDERINDUKTIVE FOLIENKONDENSATOREN**





## E51 High voltage, low inductance, long-term safe operation

In power electronics in general, but particularly in low inductance buffer circuits with higher voltages and in discharge circuits, the call for capacitors with low inductance poses problems. Traditional high voltage capacitors are filled with oil, and the generous bushings required for clearance/creepage as well as internal safety mechanisms add substantially to the self-inductance of the capacitor.

Based on decades of proprietary experience in metallizing capacitor films, ELECTRONICON has created a range of high voltage capacitors in self-healing technology, using the opportunities of special metallizing patterns. Despite the high voltage ratings, our E51 range is made in dry technology and without expensive bushings. For the sake of optimised self-inductance, the E51s are made without safety mechanism; by clever internal design they can be laid out and rated in such manner that partial dielectric discharges and consequential risk of failures in the customer's application are reduced to a minimum.

### General remark

As a rule, DC capacitors with high voltage rating contain several capacitances connected in series. In certain applications, e.g. in the case of uninterrupted - or only briefly interrupted - continuous DC load, this may require the use of sharing resistors in order to avoid shifts of potential.

The capacitors of the E51 series are not equipped with internal sharing resistors as standard. Please consult us in such cases if your application requires continuous load with high DC voltages for long periods of time.

## E51 Hohe Spannungen, niedrige Induktivitäten, Langzeitbetrieb ohne Ausfälle

In der Leistungselektronik im allgemeinen, speziell in niederinduktiven Zwischenkreisen höherer Spannungen und in Entladeschaltungen ist die Forderung nach niederinduktiven Kondensatoren mit Problemen verbunden: Traditionelle Hochspannungskondensatoren sind mit Öl gefüllt, und die für die Luft- und Kriechstrecken großzügig auszuliegenden Anschlussisolatoren wie auch der interne Sicherheitsmechanismus tragen wesentlich zur Eigeninduktivität des Kondensators bei.

Basierend auf jahrzehntelanger eigener Erfahrung bei der Metallisierung von Kondensatorfolien hat ELECTRONICON unter Nutzung spezieller Metallisierungsarten eine Reihe von Hochspannungskondensatoren in selbstheilender Technologie geschaffen. Trotz der hohen Spannungsnennwerte wird die E51 Reihe in trockener Technologie und ohne aufwändige Anschlüsse gefertigt. Im Interesse einer optimierten niedrigen Eigeninduktivität werden die E51er ohne Sicherheitsmechanismus gebaut; durch ein ausgeklügeltes Design können sie so ausgelegt und bemessen werden, dass dielektrische Teilentladungen und das resultierende Ausfallrisiko in der Anwendung des Kunden auf ein Minimum reduziert werden.

### Allgemeiner Hinweis

DC-Kondensatoren mit hohen Nennspannungen enthalten in der Regel in Serie geschaltete Kapazitäten. In bestimmten Anwendungsfällen, z.B. bei ununterbrochener oder nur kurzzeitig unterbrochener DC-Dauerbelastung kann dies den Einsatz von Symmetrierwiderständen erforderlich machen, um Potentialverschiebungen zu vermeiden.

Die Kondensatoren der Baureihe E51 sind standardmäßig nicht mit internen Symmetrierwiderständen ausgerüstet. Bitte konsultieren Sie uns in solchen Fällen, wenn Ihre Anwendung über längere Zeiträume hinweg eine durchgehende Belastung mit hohen DC-Spannungen vorsieht.



## E53/E55

### All in one: High rms and surge currents combined with low self-inductance

Basically, the design of our E53 capacitors is very similar to E51. Using sophisticated metallizing patterns, our SINECUT™ slitting technology, and clever winding geometries, the E53 series has a particularly low series resistance and high pulse strength. Therefore they are especially suited for the damping of GTO thyristors and low-inductance buffer circuits with high rms currents. Their very low self-inductance makes them also suitable for use in high-current applications with medium frequencies.

Along with their very good ratio of capacitance to volume, the capacitors of the E51 and E53 product families do also have high pulse strength and very good self-healing characteristics without loss or shift of capacitance. The capacitors of our E55 series, which are very similar in design and electrical features, have been optimized particularly for large capacitances at high operating voltages.

All the capacitors described above are housed in flame-retardant plastic cans (V0) and filled with solid resin. Special care has been taken both in terms of design and conservative electrical rating to ensure reliable operation even under tough environmental conditions. Connection is usually made through robust axial terminals with internal thread. The E53H-range is based on the same construction and technology principles but allows for radial connection through robust studs with M8 thread; it has two brackets at the base of the can which make for convenient mounting.

#### Important notice

Our capacitor series are made with self-healing dielectric. Self-healing breakdowns become less likely, or impossible, under high thermal or electrical overstress. The disintegration of the polypropylene dielectric may produce considerable amounts of gas accompanied by a build-up of internal pressure. Very frequent and large-scale occurrence of self-healing breakdowns (e.g., as a result of strong voltage overstrain) may cause a gradual rise of the internal pressure as well.

For the sake of lowest available self-inductance and maximum mounting comfort, the capacitors of our E51/E53/E55 ranges are not equipped with an integrated safety mechanism. They should therefore not be operated beyond their rated values and be allocated in uncritical environment (non-flammable materials) where the release of flammable organic gases or an ignition of the polypropylene cannot cause consequential damage.

## E53/E55

### Alles in einem: hohe Effektiv- und Spitzenströme UND geringe Eigeninduktivität

Kondensatoren der E53-Reihe zeichnen sich durch einen besonders geringen Serienwiderstand und hohe Stoßstromfestigkeit aus. Durch die Nutzung einzigartiger Metallisierungsmuster, unsere SINECUT™ Schneidtechnologie und ausgeklügelte Wickelgeometrien eignen sie sich besonders zum Bedämpfen von GTO-Thyristoren und in Zwischenkreisen mit hohen Effektivströmen. Ihre sehr niedrige Eigeninduktivität ermöglicht darüber hinaus auch den Einsatz in Hochstrom-Anwendungen im mittleren Frequenzbereich.

Neben ihrem günstigen Verhältnis von Kapazität und Volumen zeichnen sich die Kondensatoren der E51- und E53-Produktfamilien durch eine sehr hohe Stoßstromfestigkeit und exzellente Selbstheilfähigkeit ohne Kapazitätsverluste oder -verschiebungen aus. Die in Aufbau und Eigenschaften sehr ähnlichen E55-Kondensatoren sind auf große Kapazitäten bei gleichzeitig hohen Spannungswerten optimiert.

Alle o.a. Kondensatoren sind in flammhemmenden Gehäusen (V0) untergebracht und mit Harz vergossen. Sowohl im Design als auch in der konservativen elektrischen Auslegung wurde großer Wert auf zuverlässiges Funktionieren auch unter schwierigen Umgebungsbedingungen gelegt. Der elektrische Anschluss wird über robuste axiale Anschlüsse mit Innengewinde hergestellt. Die E53H-Reihe basiert auf gleichem Aufbau und technologischen Prinzipien, erlaubt jedoch einen radialen Anschluss mittels M8-Gewinde; zwei Montagelaschen am Becherboden gewährleisten eine bequeme Befestigung.

#### Wichtiger Hinweis

Alle in unseren Kondensatoren verwendeten dielektrischen Strukturen sind selbstheilend. Der zuverlässige Ablauf selbstheilender Durchschläge kann jedoch durch hohe thermische oder elektrische Belastung beeinträchtigt oder verhindert werden. Sich zersetzendes Polypropylen erzeugt dann größere Mengen an Gas und der Innendruck im Kondensator steigt. Gleichermaßen können großflächig auftretende Durchschläge (z.B. infolge starker Überspannung) einen starken Anstieg des Innendrucks verursachen. Zum Zwecke niedrigster Eigeninduktivität und maximalen Einbaukomforts verfügen die Kondensatoren der E51/E53/E55-Reihen nicht über einen internen Abschaltmechanismus. Sie sollten daher nicht außerhalb ihrer zulässigen Nennwerte betrieben und stets in unkritischer Umgebung (nichtentflammbare Materialien) platziert werden, wo die Freisetzung entzündlicher organischer Gase bzw. eine Entzündung des Dielektrikums keine schwerwiegenden Folgeschäden verursachen können.



E51  
DC  
2300...3800V DC

for latest edition and updates  
check [www.powercapacitors.info](http://www.powercapacitors.info)



**Axial Low-inductance DC-Capacitors**  
Niederinduktive Gleichspannungskondensatoren in axialer Bauform



**Standards** ..... IEC 61071, optional IEC 61881  
**can Gehäuse** ..... plastic Kunststoff (UL94: V0)

**mounting position** ..... optional  
**Einbaulage** ..... beliebig  
**filling material** ..... solid, based on vegetable oil, non-PCB  
**Füllmittel** ..... ausgehärtet, auf Pflanzenölbasis, PCB-frei

**Internal protection** ..... none  
**Interne Sicherung** ..... keine  
**fire load Brandlast** ..... 40 MJ/kg

**C<sub>N</sub> tolerance Toleranz** ..... ±10% (optional ±5%)  
**tanδ<sub>0</sub>** ..... 2 × 10<sup>-4</sup>

**operating temperatures Grenztemperaturen**  
**Θ<sub>min</sub> ... Θ<sub>max</sub>** ..... -25 ... +70°C  
**Θ<sub>HOTSPOT</sub>** ..... ≤ 70°C

**storing temperature Lagertemperatur** ..... -40 ... +85°C  
**Failure rate Ausfallrate** ..... 50 FIT

(reference interval\_Referenzintervall 100000 h, Θ<sub>HOTSPOT</sub> ≤ 70°C)



U <sub>N</sub> DC (V)	C <sub>N</sub> (μF)	U <sub>r</sub> (V)	U <sub>s</sub> (V)	U <sub>BB</sub> DC (V)	R <sub>s</sub> (mΩ)	R <sub>th</sub> (K/W)	I <sub>max</sub> (A)	Î (kA)	I <sub>s</sub> (kA)	L <sub>e</sub> (nH)	D <sub>1</sub> × L <sub>1</sub> (mm)	m (kg)	order no. Bestell-Nr.	pcs. Stk / Box	
<b>U<sub>N</sub> 2300V ... 2700V DC</b>															
2300	80	400	4100	3795	1.3	3.6	50	4	13	80	64 × 355	1.2	E51.L35-803R20	10/FB15	
2300	170	400	4100	3450	0.6	2.4	90	6	17	100	90 × 355	2.4	E51.P35-174R20	5/FB15	
2700	40	500	4050	4455	0.85	2.55	40	5	15	20	140 × 125	2	E51.S12-403R20	4/FB12	
<b>U<sub>N</sub> 3000V ... 3800V DC</b>															
3000	10	600	4500	4950	0.47	4.9	100	3.6	10.8	80	90 × 170	1.1	E51.P17-103R20	10/FB15	
3000	18	600	4500	4950	0.62	5.5	65	2.8	8.4	80	90 × 150	1.1	E51.P15-183R21	10/FB10	
3000	80	700	4500	4950	1.9	3.2	60	3.2	9.6	60	90 × 255	1.7	E51.P25-803R20	5/FB12	
3000	84	600	4500	4950	1.3	3.4	60	3.2	9.6	50	90 × 245	1.6	E51.P24-843R20	5/FB12	
3000	145	600	4500	4500	0.94	2.6	80	5.6	16.8	50	116 × 245	2.7	E51.R24-154R20	3/FB12	
3000	320	600	4500	4500	1	1.7	75	8.5	25.5	50	140 × 320	5.2	E51.S32-324R20	2/FB12	
3100	86	500	5600	5115	1.5	2.4	65	4.5	13	100	90 × 355	2.4	E51.P35-863R20	5/FB15	
3200	15	700	4800	5280	2.3	5.8	35	1	3	50	64 × 200	0.7	E51.L20-153R20	10/FB8	
3200	33	700	4800	5280	0.7	4.1	70	2.5	7.5	50	90 × 200	1.3	E51.P20-333R20	5/FB8	
3400	56	1000	5100	5610	5.2	3.2	20	1.4	4.2	60	90 × 255	1.7	E51.P25-563R20	5/FB12	
3500	50	600	5250	5775	1	2.3	70	4.5	13.5	80	90 × 355	2.4	E51.P35-503R20	5/FB15	
3500	500	600	5250	5250	1.2	0.75	100	13.9	41.7	200	140 × 710	11.5	E51.S71-504R20	5/FB22	
3600	80	600	5400	5940	0.71	2.6	90	6	18	40	116 × 245	2.7	E51.R24-803R20	3/FB12	
3600	220	800	5400	5400	0.6	1.1	40	4.4	13.2	40	140 × 300	5	E51.S30-224R20	2/FB12	
3800	6	600	5700	5700	1.7	13.8	10	0.97	2.91	50	90 × 60	0.4	E51.P60-602R20	10/FB2	

Other values and dimensions available on request  
Andere Werte und Abmessungen auf Anfrage erhältlich



E51  
DC  
4000...9350V DC



$U_N$ DC (V)	$C_N$ ( $\mu$ F)	$U_r$ (V)	$U_s$ (V)	$U_{BB}$ DC (V)	$R_s$ (m $\Omega$ )	$R_{th}$ (K/W)	$I_{max}$ (A)	$\hat{i}$ (kA)	$I_s$ (kA)	$L_e$ (nH)	$D_1 \times L_1$ (mm)	m (kg)	order no. Bestell-Nr.	pcs. Stk / Box
<b><math>U_N</math> 4000V ... 6300V DC</b>														
4000	16	2850	6000	6600	1.1	3.1	30	3.8	11.4	100	140 × 170	2.7	E51.S17-163R20	2/FB8
4000	215	800	6000	6000	0.7	0.95	100	11.9	35.7	60	140 × 565	9	E51.S56-224R20	4/FB22
4200	8	800	6300	6930	4.3	8.3	15	0.69	2.07	60	64 × 138	0.5	E51.L14-802R20	10/FB0
4200	45	800	6300	6930	1.6	2.4	50	4.2	12.6	80	90 × 355	2.4	E51.P35-453R20	5/FB15
4400	8	950	6600	7260	4.2	6.5	20	0.85	2.55	60	64 × 180	0.6	E51.L18-802R20	10/FB8
4500	25	950	6750	7430	0.98	4.6	50	3.1	9.3	60	90 × 188	1.3	E51.P18-253R20	5/FB15
4500	300	850	6750	6750	1.1	0.75	100	16.5	49.5	200	140 × 710	11.5	E51.S71-304R20	4/FB22
4600	2	1500	6900	7590	1.9	2.7	35	1.7	5.1	20	90 × 110	0.8	E51.P11-202R20	10/FB8
5000	4.55	1000	7500	8250	6.5	7.8	15	0.47	1.41	60	64 × 150	0.5	E51.L15-462R20	10/FB0
5600	0.1	1100	8400	8400	6.4	11.64	10	0.42	1.26	20	64 × 100	0.4	E51.L10-101R20	10/FB1
5600	1	1100	8400	8400	4.6	9.7	20	0.7	2.2	20	64 × 120	0.5	E51.L12-102R20	10/FB0
6000	5	1200	9000	9900	0.45	4.8	100	3.5	10.5	15	140 × 110	1.8	E51.S11-502R20	4/FB12
6000	30	700	9000	9000	2.3	3.2	30	2.1	6.3	80	116 × 200	2.2	E51.R20-303R20	3/FB8
6000	82	1200	9000	9000	2.2	1.56	35	4	12	100	140 × 340	5.5	E51.S34-823R20	2/FB12
6200	6.8	1200	9300	9300	10	4.6	20	0.6	2	50	64 × 255	0.9	E51.L25-682R20	10/FB12
6200	15	1200	9300	9300	4.6	3.2	35	1.5	4.5	50	90 × 255	1.7	E51.P25-153R20	5/FB12
6300	20	1200	9450	9450	6.8	2.4	25	1.8	8	100	90 × 355	2.4	E51.P35-203R20	5/FB15
6300	51.25	1250	9450	9450	2.7	1.5	40	4.3	20	80	140 × 355	5.7	E51.S35-513R20	2/FB12
<b><math>U_N</math> 8000V ... 9350V DC</b>														
8000	5	1400	12000	12000	1.7	3.76	50	1.8	5	80	90 × 220	1.5	E51.P22-502R20	5/FB8
8000	10	1400	12000	12000	2.3	2.59	50	1.9	6	100	90 × 320	2.2	E51.P32-103R20	5/FB12
8000	39	1400	12000	12000	3.9	1.5	40	2.7	8.1	100	140 × 355	5.7	E51.S35-393R20	2/FB12
8500	0.5	3950	12750	12750	3.9	7.1	20	0.54	1.62	60	64 × 165	0.6	E51.L16-501R20	10/FB7
8500	1	1400	12750	12750	4.1	5	25	1.7	5.1	50	90 × 160	1.1	E51.P16-102R20	10/FB15
9300	9	1500	13950	13950	8	2.4	20	1	4	100	90 × 355	2.4	E51.P35-902R20	5/FB15
9300	25	1500	13950	13950	2.7	1.5	40	4	11	100	140 × 355	5.7	E51.S35-253R20	2/FB12
9350	10	1500	14025	14025	6.6	2.3	10	1.3	3.9	100	90 × 355	2.4	E51.P35-103R20	5/FB15

Other values and dimensions available on request  
Andere Werte und Abmessungen auf Anfrage erhältlich



E51  
DC  
10000...40000V DC

for latest edition and updates  
check [www.powercapacitors.info](http://www.powercapacitors.info)



U <sub>N</sub> DC (V)	C <sub>N</sub> (μF)	U <sub>r</sub> (V)	U <sub>s</sub> (V)	U <sub>BB</sub> DC (V)	R <sub>s</sub> (mΩ)	R <sub>th</sub> (K/W)	I <sub>max</sub> (A)	Î (kA)	I <sub>s</sub> (kA)	L <sub>e</sub> (nH)	D <sub>1</sub> × L <sub>1</sub> (mm)	m (kg)	order no. Bestell-Nr.	pcs Stk / Box
<b>U<sub>N</sub> 10000V ... 40000V DC</b>														
10000	0.25	2000	15000	15000	15.2	7.1	10	1.1	3.3	80	64 × 165	0.6	E51.L16-251R20	10/FB7
11000	21	2300	16500	16500	2.6	1.5	35	3	9	100	140 × 355	5.7	E51.S35-213R20	2/FB12
12000	0.2	1400	18000	18000	4.2	4.6	26	0.5	1.4	120	64 × 255	0.9	E51.L25-201R20	10/FB12
12000	24	2100	18000	18000	4.2	0.95	25	4.2	12.6	60	140 × 565	9	E51.S56-243R20	4/FB22
12500	0.22	2100	18750	18750	14	5.8	14	0.5	1.4	80	64 × 200	0.7	E51.L20-221R20	10/FB8
12500	0.25	2100	18750	18750	14	5.8	14	0.5	1.5	80	64 × 200	0.7	E51.L20-251R20	10/FB8
12500	1	2100	18750	18750	3.6	3.2	35	2	6	100	116 × 200	2.2	E51.R20-102R20	3/FB8
13000	0.25	3000	19500	19500	17.7	4.1	10	0.6	1.7	100	64 × 285	1	E51.L28-251R20	10/FB12
14000	10	2400	21000	21000	2.4	1.5	40	4.3	12.9	120	140 × 355	5.7	E51.S35-103R20	2/FB12
15000	1	3600	22500	22500	15.1	4.1	15	0.49	1.47	100	64 × 285	1	E51.L28-102R20	10/FB12
15000	2	3600	22500	22500	7.2	2.9	20	1.1	3.3	200	90 × 285	1.9	E51.P28-202R20	5/FB12
15000	3	3600	22500	22500	3.7	0.7	20	5.4	16.2	200	140 × 710	11.5	E51.S71-302R20	4/FB22
15000	10	3600	22500	22500	2.7	1.4	40	3.8	11.4	120	140 × 385	6.2	E51.S38-103R20	4/FB0
15000	15	3600	22500	22500	2.8	1.2	40	4.6	13.8	120	140 × 460	7.4	E51.S46-153R20	4/FB22
20000	1.25	4000	30000	30000	11.7	2.3	20	0.9	2.7	100	90 × 355	2.4	E51.P35-132R20	5/FB15
20000	1.5	4000	30000	30000	10.4	2.3	34	1.8	5.4	100	90 × 355	2.4	E51.P35-152R20	5/FB15
20000	2	4000	30000	30000	10	1.84	20	1.3	3.9	100	90 × 450	3	E51.P45-202R20	6/FB23
20000	5	4000	30000	30000	2.5	1.9	25	2.7	8.1	100	140 × 285	4.6	E51.S28-502R20	2/FB12
20000	10	4000	30000	30000	4.8	0.9	25	2.8	8.4	60	140 × 565	9.1	E51.S56-103R20	4/FB22
20000	20	4000	30000	30000	6.6	0.6	25	3.1	9.3	240	140 × 850	13.8	E51.S85-203R20	4/FB25
25000	10	4600	37500	37500	3.9	0.75	35	4.3	12.9	200	140 × 710	11.5	E51.S71-103R20	4/FB22
30000	1	4800	45000	45000	11	1.9	20	1	3	80	90 × 450	2.9	E51.P44-102R20	6/FB37
30000	5	4800	45000	45000	7	0.75	35	2.8	8.4	200	140 × 710	11.5	E51.S71-502R20	4/FB22
31250	6.67	5900	46875	46875	5.3	0.68	25	3.6	10.8	200	140 × 785	12.7	E51.S78-672R20	4/FB25
35000	0.2	5600	52500*	52500*	13.4	1.9	20	1	3	80	90 × 435	2.9	E51.P44-201R20	6/FB37
35000	5	4800	52500**	52500**	5.5	0.68	25	3.2	9.6	200	140 × 785	12.7	E51.S78-502R20	4/FB25
40000	2.2	8700	60000	60000	5.3	0.84	35	2.8	8.4	180	140 × 630	10.2	E51.S63-222R20	4/FB22

\* additional test\_Zusatzprüfung 14500V<sub>rms</sub>/10s  
\*\* additional test\_Zusatzprüfung 16500V<sub>rms</sub>/10s





# 1050...3400V AC / 3200...4750V DC

## Axial Low-inductance AC/DC-Capacitors Niederinduktive Wechsel-/Gleichspannungskondensatoren in axialer Bauform



**Standards** ..... IEC 61071, optional IEC 61881

**can Gehäuse** ..... plastic Kunststoff (UL94: VO)

**mounting position Einbaulage**... optional beliebig

**filling material** ..... solid, based on vegetable oil, non-PCB

**Füllmittel**..... ausgehärtet, auf Pflanzenölbasis, PCB-frei

**Internal protection**..... none

**Interne Sicherung** ..... keine

**fire load Brandlast** ..... 40 MJ/kg

**C<sub>N</sub> tolerance Toleranz** ..... ±10% (optional ±5%)

**tanδ<sub>0</sub>** ..... 2 × 10<sup>-4</sup>

**operating temperatures Grenztemperaturen**

    Θ<sub>min</sub> ... Θ<sub>max</sub> ..... -25 ... +70°C

    Θ<sub>HOTSPOT</sub> ..... ≤ 70°C

**storing temperature Lagertemperatur** ..... -40 ... +85°C

**Failure rate Ausfallrate** ..... 100 FIT

(reference interval\_Referenzintervall 100000 h, Θ<sub>HOTSPOT</sub> ≤ 70°C)

U <sub>N</sub> AC (V)	U <sub>N</sub> DC (V)	C <sub>N</sub> (µF)	U <sub>rms</sub> (V)	U <sub>s</sub> (V)	U <sub>BB</sub> (V)	R <sub>s</sub> (mΩ)	R <sub>th</sub> (K/W)	I <sub>max</sub> (A)	I <sub>1</sub> (kA)	I <sub>s</sub> (kA)	L <sub>e</sub> (nH)	D <sub>1</sub> × L <sub>1</sub> (mm)	m (kg)	order no. Bestell-Nr.	pcs_Stk / Box
<b>U<sub>N</sub> 1050V ... 2900V AC</b>				<b>U<sub>rms</sub> 750V ... 2050 V</b>											
1050	3200	6	750	4800	5280 (DC)	0.44	4.9	100	2.7	8.1	30	90 × 170	1.1	E51.P17-602R20	10/FB15
1300	1850	4.7	920	2775	3080 (DC)	2.6	9.7	10	1.1	3.3	60	64 × 120	0.4	E51.L12-472R20	10/FB0
1530	2500	4	1080	3750	4125 (DC)	1.7	5.9	50	1.8	5.4	50	64 × 138	0.5	E51.L14-402R10	10/FB0
1750	3000	4	1250	4500	4950 (DC)	0.99	4	80	4.8	12	20	90 × 145	1	E51.P14-402R20	10/FB10
2450	3750	1.5	1750	5625	6190 (DC)	0.66	3.8	80	3	9	15	116 × 60	0.8	E51.R60-152R20	12/FB12
2450	6000	2	1700	9000	9900 (DC)	2.8	5.9	45	1.5	4.4	60	90 × 140	0.9	E51.P14-202R20	10/FB10
2500	6000	1	1770	9000	9000 (DC)	3.2	6.4	28	0.98	2.94	30	90 × 130	0.9	E51.P13-102R20	10/FB12
2500	7000	2	1770	10500	11500 (DC)	2.8	5.52	25	1.3	3.9	25	90 × 150	1	E51.P15-202R20	10/FB10
2550	3200	1	1800	4800	5483 (DC)	1.8	9.7	40	2	5	40	64 × 120	0.5	E51.L12-102R21	10/FB0
2600	3800	0.75	1850	5700	5700 (DC)	4.1	4.1	45	1.35	3.1	15	64 × 100	0.3	E51.L10-751R21	10/FB1
2600	3800	1.5	1850	5700	5700 (DC)	1.8	2.9	70	3.1	7.4	15	90 × 100	0.7	E51.P10-152R21	10/FB8
2700	4400	4	1910	6600	6600 (DC)	0.62	5.8	90	2.2	7	15	116 × 110	1.5	E51.R11-402R20	6/FB12
2900	2900	0.6	2050	4350	6860 (DC)	3.9	4.1	15	0.69	2.1	30	64 × 100	0.3	E51.L10-601R21	10/FB1
2900	3000	3	2050	7500	8250 (DC)	0.74	5.8	80	2	6	15	116 × 110	1.5	E51.R11-302R20	6/FB12
<b>U<sub>N</sub> 3000V ... 3400V AC</b>				<b>U<sub>rms</sub> 2100V ... 2400 V</b>											
3000	3000	0.47	2100	6450	6450 (DC)	3.2	11.6	15	1.1	3.3	60	64 × 100	0.34	E51.L10-471R20	10/FB1
3000	3250	5	2200	7000	5000 (AC)	3.8	2.5	10	2	6	80	116 × 260	2.7	E51.R26-502R20	3/FB12
3200	3400	0.47	2250	9750	9750 (DC)	7.4	9.7	20	0.5	1.5	60	64 × 120	0.4	E51.L12-471R20	10/FB0
3200	3400	0.5	2260	10920	10920 (DC)	5	9	25	0.62	1.86	60	64 × 130	0.4	E51.L13-501R20	10/FB0
3200	3400	0.68	2250	8175	9000 (DC)	4.6	9.7	20	1	2.94	60	64 × 120	0.5	E51.L12-681R20	10/FB0
3250	3700	0.75	2300	4875	4875 (AC)	4.9	7.1	20	0.92	2.76	100	64 × 165	0.6	E51.L16-751R20	10/FB7
3400	4000	1.8	2400	6000	7310 (DC)	3.7	4.1	25	1.5	4.5	60	90 × 200	1.3	E51.P20-182R21	5/FB8
3400	4700	2.2	2400	6000	8050 (DC)	2.6	4.1	25	2.2	6.6	60	90 × 200	1.3	E51.P20-222R20	5/FB8
3400	4750	4.8	2400	6000	7310 (DC)	1.5	3.2	35	2.1	6	100	116 × 200	2.2	E51.R20-482R21	3/FB8



E51  
AC/DC  
3500...4950V AC / 4950...21000V DC

for latest edition and updates  
check [www.powercapacitors.info](http://www.powercapacitors.info)



**Axial Low-inductance AC/DC-Capacitors**  
Niederinduktive Wechsel-/Gleichspannungskondensatoren  
in axialer Bauform



**Standards** ..... IEC 61071, optional IEC 61881

**can Gehäuse** ..... plastic Kunststoff (UL94: V0)

**mounting position Einbaulage**... optional beliebig

**filling material** ..... solid, based on vegetable oil, non-PCB

**Füllmittel**..... ausgehärtet, auf Pflanzenölbasis, PCB-frei

**Internal protection** ..... none

**Interne Sicherung** ..... keine

**fire load Brandlast** ..... 40 MJ/kg

**C<sub>N</sub> tolerance Toleranz** ..... ±10% (optional ±5%)

**tanδ<sub>0</sub>** ..... 2 × 10<sup>-4</sup>

**operating temperatures Grenztemperaturen**

Θ<sub>min</sub> ... Θ<sub>max</sub> ..... -25 ... +70°C

Θ<sub>HOTSPOT</sub> ..... ≤ 70°C

**storing temperature Lagertemperatur** ..... -40 ... +85°C

**Failure rate Ausfallrate** ..... 100 FIT

(reference interval\_Referenzintervall 100000 h, Θ<sub>HOTSPOT</sub> ≤ 70°C)



U <sub>N</sub> AC (V)	U <sub>N</sub> DC (V)	C <sub>N</sub> (μF)	U <sub>rms</sub> (V)	U <sub>S</sub> (V)	U <sub>BB</sub> (V)	R <sub>S</sub> (mΩ)	R <sub>th</sub> (K/W)	I <sub>max</sub> (A)	I <sub>h</sub> (kA)	I <sub>S</sub> (kA)	L <sub>e</sub> (nH)	D <sub>1</sub> × L <sub>1</sub> (mm)	m (kg)	order no. Bestell-Nr.	pcs_Stk / Box
<b>U<sub>N</sub> 3500V ... 3700V AC</b>			<b>U<sub>rms</sub> 2500V ... 2600 V</b>												
3500	4950	0.15	2500	5250	9900 (DC)	2.2	9.7	20	0.4	1.1	60	64 × 120	0.4	E51.L12-151R20	10/FB0
3500	5000	0.22	2500	9000	9000 (DC)	4.8	9.7	20	0.7	2.1	60	64 × 120	0.4	E51.L12-221R20	10/FB0
3500	5100	0.33	2500	9000	9000 (DC)	3	9.7	20	0.98	2.94	60	64 × 120	0.5	E51.L12-331R20	10/FB0
3500	5100	0.5	2500	9000	9000 (DC)	5.6	9.7	20	1	3	60	64 × 120	0.4	E51.L12-501R20	10/FB0
3500	5200	0.68	2500	7500	7500 (DC)	4.9	3.2	40	0.76	2.28	15	64 × 130	0.4	E51.L13-681R20	10/FB0
3500	5500	1.25	2500	9000	9900 (DC)	2.2	6.4	45	1.4	4.2	60	90 × 130	0.9	E51.P13-132R20	10/FB12
3500	6000	1.5	2500	9000	9000 (DC)	2.2	6.4	45	1.5	4.4	60	90 × 130	0.9	E51.P13-152R20	10/FB12
3550	6500	0.73	2500	7800	8410 (DC)	4.6	3.2	20	0.86	2.58	20	64 × 130	0.4	E51.L13-731R20	10/FB0
3650	7000	0.1	2575	7500	8635 (DC)	7.4	5.3	20	0.4	1.3	15	64 × 78	0.3	E51.L78-101R20	10/FB2
3700	7500	1.5	2600	5600	8000 (AC)	3.6	3	15	2.2	6.6	100	90 × 285	1.9	E51.P28-152R20	5/FB12
<b>U<sub>N</sub> 4000V ... 4950V AC</b>			<b>U<sub>rms</sub> 2825V ... 3500 V</b>												
4000	8900	0.3	2825	6000	5500 (DC)	10.4	4.2	5	0.78	2.34	100	64 × 275	0.9	E51.L27-301R70	10/FB12
4550	8900	0.22	3200	10920	10920 (DC)	8.9	9	15	0.34	1.02	60	64 × 130	0.4	E51.L13-221R20	10/FB0
4550	10000	0.33	3200	10920	10920 (DC)	6.7	9	20	0.46	1.38	60	64 × 130	0.4	E51.L13-331R20	10/FB0
4550	13800	2	3200	10920	10920 (DC)	1.3	1.7	55	2.4	7.2	60	116 × 130	1.4	E51.R13-202R20	6/FB12
4700	15000	1	3200	7050	6880 (AC)	3.8	3	10	2.2	6.6	100	90 × 275	1.8	E51.P27-102R20	5/FB12
4750	15000	1	2200	10000	7000 (AC)	5.2	2.3	10	1.5	4	80	90 × 355	2.4	E51.P35-102R20	5/FB15
4920	15000	3.75	3480	12300	12300 (DC)	1.3	2.7	15	4.8	14.4	100	140 × 200	3.2	E51.S20-382R20	2/FB8
4950	15560	0.25	3500	9000	11710 (DC)	5	7.1	15	1.15	3.45	100	64 × 165	0.6	E51.L16-251R21	10/FB7
4950	21000	0.5	3500	10000	8500 (AC)	6	4.2	10	1	2.5	100	64 × 275	0.9	E51.L27-501R70	10/FB12

Other values and dimensions available on request  
Andere Werte und Abmessungen auf Anfrage erhältlich



5000...21250V AC / 5000...50000V DC

U <sub>N</sub> AC (V)	U <sub>N</sub> DC (V)	C <sub>N</sub> (µF)	U <sub>rms</sub> (V)	U <sub>S</sub> (V)	U <sub>BB</sub> (V)	R <sub>S</sub> (mΩ)	R <sub>th</sub> (K/W)	I <sub>max</sub> (A)	Î (kA)	I <sub>S</sub> (kA)	L <sub>e</sub> (nH)	D <sub>1</sub> × L <sub>1</sub> (mm)	m (kg)	order no. Bestell-Nr.	pcs_Stk / Box
<b>U<sub>N</sub> 5000V ... 6500V AC</b>			<b>U<sub>rms</sub> 3500V ... 4600 V</b>												
5000	21250	0.47	3500	7500	11825 (DC)	5.8	5.5	16	1	3	40	64 × 210	0.7	E51.L21-471R20	10/FB8
5000	10000	0.5	3540	15000	10000 (DC)	5.7	4.1	25	1	3	50	90 × 200	1.3	E51.P20-501R20	5/FB8
5100	5100	1.6	3600	9500	7100 (AC)	3	2.3	25	3	12	60	116 × 285	3	E51.R28-162R20	6/FB12
5100	5100	2.4	3600	10965	10965 (DC)	3	4.1	35	1.4	4.2	60	90 × 200	1.3	E51.P20-242R21	5/FB8
5200	5200	1.1	3700	7800	12300 (DC)	3.1	4.1	20	1.7	5.1	60	90 × 200	1.3	E51.P20-112R20	5/FB8
5200	7350	1.3	3700	11025	12300 (DC)	8.7	3.28	10	1.2	3.6	150	64 × 355	1.2	E51.L35-132R20	10/FB15
5500	5500	1.5	3900	8250	11825 (DC)	5.2	3	25	2	6	80	90 × 275	1.8	E51.P27-152R21	5/FB12
6000	6000	0.35	4250	9000	12500 (DC)	3.7	5.02	10	1.8	5.4	50	90 × 160	1.1	E51.P16-351R20	10/FB15
6300	9000	0.125	4455	13500	10000 (DC)	5.5	7.1	20	0.79	2.37	100	64 × 165	0.7	E51.L16-131R20	10/FB7
6300	9000	0.14	4500	13500	10000 (DC)	17.6	5.8	14	0.31	0.93	50	64 × 200	0.7	E51.L20-141R20	10/FB8
6500	6500	4	4600	9500	14000 (DC)	1.7	1.5	12	7	21	150	140 × 355	6	E51.S35-402R20	2/FB12
<b>U<sub>N</sub> 7000V ... 9500V AC</b>			<b>U<sub>rms</sub> 5000V ... 6700 V</b>												
7000	7000	0.018	5000	10000	8750 (AC)	17	5.5	5	0.3	1	40	64 × 210	0.8	E51.L21-180R20	10/FB8
7100	13000	0.25	5000	19500	10000 (DC)	17.7	4.1	10	0.6	1.7	100	64 × 285	1	E51.L28-251R21	10/FB12
7500	7500	1.33	5300	11250	16125 (DC)	3.9	1.5	10	2.5	7.5	100	140 × 355	5.7	E51.S35-132R20	2/FB12
8900	8900	0.1	6300	13500	10000 (DC)	8.5	6	15	0.8	2.3	50	64 × 210	0.7	E51.L21-101R20	10/FB8
8900	8900	0.24	6300	13350	10000 (DC)	5	3.8	20	2	6	60	90 × 215	1.4	E51.P21-241R20	5/FB8
9500	15000	0.5	6700	22500	10000 (DC)	5.5	2.51	10	2.7	8.1	80	90 × 330	2.2	E51.P33-501R20	5/FB15
<b>U<sub>N</sub> 10000V ... 21250V AC</b>			<b>U<sub>rms</sub> 7070V ... 15000 V</b>												
10000	10000	0.5	7070	15000	21500 (DC)	7.2	1.44	10	1	3	100	90 × 355	2.4	E51.P35-501R20	5/FB15
13800	13800	0.04	9760	20700	20700 (AC)	38	3	0.3	0.32	0.96	150	64 × 385	1.3	E51.L38-041R20	10/FB15
14150	30000	1	10000	45000	45000 (DC)	5.7	0.7	10	4.9	14.7	200	140 × 710	11.5	E51.S71-102R20	4/FB22
15000	15000	0.006	10600	22500	26250 (AC)	67	2	5	0.3	1	120	64 × 570	2	E51.L57-600R20	8/FB31
15000	15000	0.0072	10600	22500	26250 (AC)	56	2	5	0.35	1.05	120	64 × 570	2	E51.L57-720R20	8/FB31
15000	15000	0.009	10600	22500	26250 (AC)	45	2	5	0.43	1.29	120	64 × 570	2	E51.L57-900R20	8/FB31
15560	15560	0.03	11000	23340	10000 (DC)	19.2	4.2	0.3	0.51	1.53	100	64 × 275	0.9	E51.L27-300R20	10/FB12
20000	26000	0.3	14000	30000	43000 (DC)	3.1	1.8	10	8	20	100	116 × 355	4	E51.R35-301R20	3/FB15
20000	50000	0.5	14140	60000	45850 (AC)	6.2	0.8	10	8.5	20	200	140 × 710	11.5	E51.S71-501R20	4/FB22
21000	21000	0.004	15000	31500	33000 (AC)	0.97	1.4	1	0.3	0.8	150	64 × 810	2.8	E51.L81-040R20	10/FB25
21250	21250	1	15000	31875	45690 (DC)	46	0.68	2	5.2	15.6	200	140 × 785	12.7	E51.S78-102R20	4/FB25



E53  
AC/DC  
280...350V AC / 550...1400V DC

for latest edition and updates  
check [www.powercapacitors.info](http://www.powercapacitors.info)



**Axial Low-inductance AC/DC-Capacitors**  
Niederinduktive Wechsel-/Gleichspannungskondensatoren  
in axialer Bauform



**Standards** ..... IEC 61071, UL810, CSA 22.2 No.190  
optional IEC 61881

**can Gehäuse** ..... plastic Kunststoff (UL94: V0)

**mounting position Einbaulage**... optional beliebig

**filling material** ..... solid, based on vegetable oil, non-PCB

**Füllmittel**..... ausgehärtet, auf Pflanzenölbasis, PCB-frei

**Internal protection**..... none

**Interne Sicherung** ..... keine

**fire load Brandlast** ..... 40 MJ/kg

**C<sub>N</sub> tolerance Toleranz**..... ±10% (optional ±5%)

**self-inductance Eigeninduktivität L<sub>e</sub>** ..... ca. 15 nH

**tanδ<sub>0</sub>** ..... 2 × 10<sup>-4</sup>

**operating temperatures Grenztemperaturen**

Θ<sub>min</sub> ... Θ<sub>max</sub> ..... -40 ... +85°C

Θ<sub>HOTSPOT</sub> ..... ≤ 85°C

**storing temperature Lagertemperatur** ..... -40 ... +85°C

**Failure rate Ausfallrate** ..... 100 FIT

(reference interval\_Referenzintervall 100000 h, Θ<sub>HOTSPOT</sub> ≤ 70°C)



C <sub>N</sub> (μF)	U <sub>pk</sub> (VDC)	U <sub>S</sub> (nH)	U <sub>BB</sub> (K/W)	R <sub>S</sub> (mΩ)	L <sub>e</sub> (nH)	R <sub>th</sub> (K/W)	I <sub>max</sub> (A)	I <sub>1</sub> (kA)	I <sub>S</sub> (kA)	D <sub>1</sub> × L <sub>1</sub> (mm)	Design Maßbild	m (kg)	L/K (mm)	order no. Bestell-Nr.	pcs_Stk / Box
<b>U<sub>N</sub> 280V AC      U<sub>rms</sub> 200V</b>															
50	550	825	825	0.8	15	8.5	60	0.83	2.49	55 × 56	T1	0.2	97	E53.H56-503T10	15/FB6
100	550	825	825	0.35	15	6.3	80	1.7	5	75 × 56	T2	0.3	111	E53.M56-104T20	10/FB2
200	550	825	825	0.2	15	4.9	80	3.3	9.9	95 × 56	T2	0.5	131	E53.P56-204T20	10/FB2
250	550	825	825	0.15	15	4.5	80	4.1	12.3	105 × 56	T2	0.6	141	E53.Q56-254T20	10/FB2
270	550	825	825	0.15	15	4.1	100	3.3	10	115 × 56	T2	0.8	151	E53.R56-274T20	12/FB9
380	550	825	825	0.31	15	2.3	100	3	10	115 × 100	T2	1.4	195	E53.R10-384T20	6/FB8
<b>U<sub>N</sub> 350V AC      U<sub>rms</sub> 250V</b>															
28	700	1050	1050	0.65	15	9.9	55	0.68	2.1	55 × 48	T1	0.2	89	E53.H48-283T11	15/FB6
33	700	1050	1050	0.95	15	8.5	55	0.68	2.04	55 × 56	T1	0.2	97	E53.H56-333T10	15/FB6
120	700	1050	1050	0.25	15	2.7	80	3.1	9.3	95 × 56	T2	0.5	131	E53.P56-124T20	10/FB2
200	700	1050	1050	0.2	15	4.1	100	3.1	10	115 × 56	T2	0.8	151	E53.R56-204T20	12/FB9
30	900	1350	1350	0.85	15	8.5	60	0.68	2.1	55 × 56	T1	0.2	97	E53.H56-303T10	15/FB6
60	900	1350	1350	0.41	15	6.3	80	1.4	4.1	75 × 56	T2	0.3	111	E53.M56-603T20	10/FB2
100	900	1350	1350	0.25	15	4.9	80	2.3	6.8	95 × 56	T2	0.5	131	E53.P56-104T20	10/FB2
120	900	1350	1350	0.2	15	4.5	100	2.8	8.4	105 × 56	T2	0.6	141	E53.Q56-124T20	10/FB2
140	900	1350	1350	0.2	15	4.1	100	3.1	10	115 × 56	T2	0.8	151	E53.R56-144T20	12/FB9
265	900	1350	1350	0.35	15	2.3	100	3	9	115 × 100	T2	1.4	195	E53.R10-274T20	6/FB8
12	1100	1650	1650	1.7	15	8.5	40	0.4	1.2	55 × 56	T1	0.2	97	E53.H56-123T10	15/FB6
15	1100	1650	1650	1.1	15	8.5	40	0.5	1.5	55 × 56	T1	0.2	97	E53.H56-153T10	15/FB6
25	1100	1650	1650	0.71	15	6.3	70	0.83	2.5	75 × 56	T2	0.3	111	E53.M56-253T20	10/FB2
50	1100	1650	1650	0.34	15	4.9	80	1.7	5	95 × 56	T2	0.5	131	E53.P56-503T20	10/FB2
60	1100	1650	1650	0.35	15	4.5	100	2	6	105 × 56	T2	0.6	141	E53.Q56-603T20	10/FB2
80	1100	1650	1650	0.21	15	4.1	100	3	10	115 × 56	T2	0.8	151	E53.R56-803T20	12/FB9
175	1100	1650	1650	0.41	15	2.3	100	2.6	8	115 × 100	T2	1.4	195	E53.R10-184T20	6/FB9
8	1400	2100	2100	2	15	8.5	38	0.33	1	55 × 56	T1	0.2	97	E53.H56-802T10	10/FB6
16	1400	2100	2100	0.85	15	6.3	60	0.65	1.95	75 × 56	T2	0.3	111	E53.M56-163T20	10/FB2
30	1400	2100	2100	0.46	15	4.9	80	1.2	3.7	95 × 56	T2	0.5	131	E53.P56-303T20	10/FB2
40	1400	2100	2100	0.4	15	4.5	100	1.7	5.1	105 × 56	T2	0.6	141	E53.Q56-403T20	10/FB2
50	1400	2100	2100	0.27	15	4.1	100	2.2	10	115 × 56	T2	0.8	151	E53.R56-503T20	12/FB9
110	1400	2100	2100	0.52	15	2.3	100	2	6	115 × 100	T2	1.4	195	E53.R10-114T20	6/FB9

Other values and dimensions available on request

Andere Werte und Abmessungen auf Anfrage erhältlich



C <sub>N</sub> (μF)	U <sub>pk</sub> (VDC)	U <sub>S</sub> (nH)	U <sub>BB</sub> (K/W)	R <sub>S</sub> (mΩ)	L <sub>e</sub> (nH)	R <sub>th</sub> (K/W)	I <sub>max</sub> (A)	I <sub>h</sub> (kA)	I <sub>S</sub> (kA)	D <sub>1</sub> × L <sub>1</sub> (mm)	Design Maßbild	m (kg)	L/K (mm)	order no. Bestell-Nr.	pcs_Stk / Box
<b>U<sub>N</sub> 700V AC</b>		<b>U<sub>rms</sub> 500V</b>													
4.7	1700	2550	2550	1.1	15	8.5	45	0.5	1.6	55 × 56	T1	0.2	97	E53.H56-472T10	15/FB6
10	1700	2550	2550	0.6	15	6.3	80	1.1	3.5	75 × 56	T2	0.3	111	E53.M56-103T20	10/FB2
16	1700	2550	2550	0.37	15	4.9	80	1.8	5.5	95 × 56	T2	0.5	131	E53.P56-163T20	10/FB2
20	1700	2550	2550	0.26	15	4.5	100	2.3	7	105 × 56	T2	0.6	141	E53.Q56-203T20	10/FB2
22	1700	2550	2550	0.27	15	4.5	100	2.5	7.5	105 × 56	T2	0.6	141	E53.Q56-223T20	10/FB2
33	1700	2550	2550	0.2	15	4.1	100	3.5	10	115 × 56	T2	0.8	151	E53.R56-333T20	12/FB9
68	1700	2550	2550	0.35	15	2.3	100	3.1	9.3	115 × 100	T2	1.4	195	E53.R10-683T20	6/FB8
3.3	2000	3000	3000	1.6	15	8.5	40	0.42	1.2	55 × 56	T1	0.2	97	E53.H56-332T10	15/FB6
8	2000	3000	3000	0.65	15	6.3	80	1	3	75 × 56	T2	0.3	111	E53.M56-802T20	10/FB2
14	2000	3000	3000	0.35	15	4.9	80	1.8	5.5	95 × 56	T2	0.5	131	E53.P56-143T20	10/FB2
16	2000	3000	3000	0.3	15	4.2	100	2	6	105 × 56	T2	0.6	141	E53.Q56-163T20	10/FB2
18	2000	3000	3000	0.3	15	4.2	100	2.3	7	105 × 56	T2	0.6	141	E53.Q56-183T20	10/FB2
24	2000	3000	3000	0.21	15	4.1	100	3	10	115 × 56	T2	0.8	151	E53.R56-243T20	12/FB9
52.5	2000	3000	3000	0.39	15	2.3	100	2.8	8	115 × 100	T2	1.4	205	E53.R10-533T20	6/FB9
2.5	2250	3375	3375	1.8	15	8.5	40	0.37	1.1	55 × 56	T1	0.2	97	E53.H56-252T10	15/FB6
4	1900	2850	2850	1.1	15	6.3	80	1.1	3	75 × 56	T2	0.3	111	E53.M56-402T20	10/FB2
5	2250	3375	3375	0.61	15	6.3	80	0.8	2.3	75 × 56	T2	0.3	111	E53.M56-502T20	10/FB2
6	2250	3375	3375	0.76	15	6.3	80	0.88	2.6	75 × 56	T2	0.3	111	E53.M56-602T20	10/FB2
10	2250	3375	3375	0.44	15	4.9	80	1.5	4.5	95 × 56	T2	0.5	131	E53.P56-103T20	10/FB2
12	2250	3375	3375	0.37	15	4.5	100	2.5	7	105 × 56	T2	0.6	141	E53.Q56-123T20	10/FB2
15	2250	3375	3375	0.27	15	4.5	100	2.1	6.2	105 × 56	T2	0.6	141	E53.Q56-153T20	10/FB2
18	2250	3375	3375	0.25	15	4.1	100	2.6	10	115 × 56	T2	0.8	151	E53.R56-183T20	12/FB9
40	2250	3375	3375	0.45	15	2.3	100	2.4	7	115 × 100	T2	1.4	195	E53.R10-403T20	6/FB9
1.5	2800	4200	4200	2.4	15	8.5	32	0.27	1.35	55 × 56	T1	0.2	97	E53.H56-152T10	15/FB6
3.3	2800	4200	4200	1.1	15	6.3	60	0.6	3	75 × 56	T2	0.3	111	E53.M56-332T20	10/FB2
5	2200	3300	3300	0.78	15	4.9	80	2	6	95 × 56	T2	0.5	131	E53.P56-502T20	10/FB2
6.8	2800	4200	4200	0.55	15	4.9	80	1.2	6	95 × 56	T2	0.5	131	E53.P56-682T20	10/FB2
7.5	2800	4200	4200	0.5	15	4.9	80	1.5	7.5	95 × 56	T2	0.5	131	E53.P56-752T20	10/FB2
8	2800	4200	4200	0.45	15	4.5	100	1.5	7.5	105 × 56	T2	0.6	141	E53.Q56-802T20	10/FB2
10	2800	4200	4200	0.35	15	4.5	100	1.8	9	105 × 56	T2	0.6	141	E53.Q56-103T20	10/FB2
12	2800	4200	4200	0.29	15	4.1	100	2.2	12	115 × 56	T2	0.8	151	E53.R56-123T20	12/FB9
25	2800	4200	4200	0.57	15	2.3	100	1.9	6	115 × 100	T2	1.4	195	E53.R10-253T20	6/FB8



E53

AC/DC

1050V AC / 2200...5000V DC



$C_N$ ( $\mu$ F)	$U_{pk}$ (VDC)	$U_S$ (nH)	$U_{BB}$ (K/W)	$R_S$ (m $\Omega$ )	$L_e$ (nH)	$R_{th}$ (K/W)	$I_{max}$ (A)	$\hat{I}$ (kA)	$I_S$ (kA)	$D_1 \times L_1$ (mm)	Design Maßbild	m (kg)	L/K (mm)	order no. Bestell-Nr.	pcs_Stk / Box
<b><math>U_N</math> 1050V AC      <math>U_{rms}</math> 750V</b>															
4.7	2200	3300	3300	0.83	15	4.9	80	1.5	4.5	95 × 56	T2	0.5	131	E53.P56-472T20	10/FB2
22	2200	3300	3300	0.15	15	2.3	100	3.9	11.7	115 × 100	T2	1.4	195	E53.R10-223T20	6/FB8
8	2200	3300	3300	0.48	15	4.1	100	2.5	8	115 × 56	T2	0.8	151	E53.R56-802T20	12/FB9
1	2550	3825	3825	3.4	15	8.5	40	0.35	1.75	55 × 56	T1	0.2	97	E53.H56-102T10	15/FB6
1.5	3200	4800	4800	1.8	15	4.9	80	0.7	2	95 × 56	T2	0.5	131	E53.P56-152T21	10/FB2
2	2800	4200	4200	1.6	15	6.3	60	0.8	2.3	75 × 56	T2	0.3	111	E53.M56-202T20	10/FB2
2.5	2450	3675	3675	1.4	15	6.3	75	0.9	4.5	75 × 56	T2	0.3	111	E53.M56-252T20	10/FB2
3	2900	4350	4350	1	15	4.9	80	1.2	3.6	95 × 56	T2	0.5	131	E53.P56-302T21	10/FB2
4	2550	3825	3825	0.85	15	4.9	80	1.5	7.5	95 × 56	T2	0.5	131	E53.P56-402T20	10/FB2
4.5	2800	4200	4200	0.69	15	4.5	100	1.8	5	105 × 56	T2	0.6	141	E53.Q56-452T20	10/FB2
5	2550	3825	3825	0.68	15	4.5	100	1.8	9	105 × 56	T2	0.6	141	E53.Q56-502T20	10/FB2
6	2550	3825	3825	0.59	15	4.5	100	2.2	11	105 × 56	T2	0.6	141	E53.Q56-602T20	10/FB2
7	2550	3825	3825	0.51	15	4.1	100	3	12	115 × 56	T2	0.8	151	E53.R56-702T20	12/FB9
1	3850	5775	5775	2.3	15	6.3	50	0.5	1.6	75 × 56	T2	0.3	111	E53.M56-102T20	10/FB2
2.2	3200	4800	4800	1.2	15	4.9	60	1	3	95 × 56	T2	0.5	131	E53.P56-222T20	10/FB2
<b><math>U_N</math> 1400V AC      <math>U_{rms}</math> 1000V</b>															
8	3600	5400	5400	0.52	15	2.3	100	2.3	6.9	115 × 100	T2	1.4	195	E53.R10-802T20	6/FB8
10	3600	5400	5400	0.94	15	2.3	100	2.5	7.5	115 × 100	T2	1.4	195	E53.R10-103T20	6/FB8
1	2550	3825	3825	1.2	15	8.5	20	0.7	2.2	55 × 56	T1	0.2	97	E53.H56-102T11	15/FB6
1.16	2450	3675	3675	1.2	15	8.5	20	0.7	2.2	55 × 56	T1	0.2	97	E53.H56-122T10	15/FB6
4.2	2450	3675	3675	0.32	15	4.9	80	2.6	8	95 × 56	T2	0.5	131	E53.P56-422T20	10/FB2
5.2	2450	3675	3675	0.26	15	4.5	100	3	10	105 × 56	T2	0.6	141	E53.Q56-522T20	10/FB2
<b><math>U_N</math> 2100V AC      <math>U_{rms}</math> 1500V</b>															
0.22	3750	5625	5625	4.7	15	8.5	20	0.5	1.5	55 × 56	T1	0.2	97	E53.H56-221T10	15/FB6
0.33	3750	5625	5625	3.9	15	8.5	20	0.5	1.6	55 × 56	T1	0.2	97	E53.H56-331T10	15/FB6
0.47	3750	5625	5625	2.9	15	8.5	20	0.7	2.1	55 × 56	T1	0.2	97	E53.H56-471T10	15/FB6
1.1	3750	5625	5625	1.2	15	6.3	60	1.6	5	75 × 56	T2	0.3	111	E53.M56-112T20	10/FB2
1.7	3750	5625	5625	0.8	15	4.9	80	2.5	8	95 × 56	T2	0.5	131	E53.P56-172T20	10/FB2
2	3750	5625	5625	0.64	15	4.1	100	3	10	115 × 56	T2	0.8	151	E53.R56-202T20	12/FB9
2.15	3750	5625	5625	0.64	15	4.5	100	3	10	105 × 56	T2	0.6	141	E53.Q56-222T20	10/FB2
2.7	3750	5625	5625	0.51	15	4.1	100	4	12	115 × 56	T2	0.8	151	E53.R56-272T20	12/FB9
3	5000	7500	7500	1.2	15	2.3	125	2.1	6.3	115 × 100	T2	1.4	195	E53.R10-302T21	6/FB8
4	4450	6675	6675	1	15	2.3	125	2.5	7.5	115 × 100	T2	1.4	195	E53.R10-402T21	6/FB8

Other values and dimensions available on request

Andere Werte und Abmessungen auf Anfrage erhältlich



2450...4000V AC / 4000...7200V DC

$C_N$ ( $\mu$ F)	$U_{pk}$ (VDC)	$U_S$ (nH)	$U_{BB}$ (K/W)	$R_S$ (m $\Omega$ )	$L_e$ (nH)	$R_{th}$ (K/W)	$I_{max}$ (A)	$\hat{I}$ (kA)	$I_S$ (kA)	$D_1 \times L_1$ (mm)	Design Maßbild	m (kg)	L/K (mm)	order no. Bestell-Nr.	pcs_Stk / Box
<b><math>U_N</math> 2450V AC</b>		<b><math>U_{rms}</math> 1750V</b>													
0.12	4000	6000	6000	5.8	15	8.5	20	0.3	0.9	55 × 56	T1	0.2	97	E53.H56-121T10	15/FB6
0.33	4000	6000	6000	1.2	15	4.5	100	1.3	4	105 × 56	T2	0.6	141	E53.Q56-331T20	10/FB2
0.5	4000	6000	6000	0.85	15	4.5	100	1.6	5	105 × 56	T2	0.6	141	E53.Q56-501T20	10/FB2
0.5	5600	8400	8400	7.6	15	4.9	20	0.4	1.3	55 × 97	T1	0.3	138	E53.H97-501T10	18/FB3
0.2	5600	8400	8400	12.3	15	4.9	35	1.2	3.6	55 × 97	T2	0.3	132	E53.H97-201T20	18/FB3
0.22	7200	10800	10800	13.7	15	4.9	25	0.2	0.7	55 × 97	T1	0.3	138	E53.H97-221T10	18/FB3
0.25	7200	10800	10800	12.1	15	4.9	25	0.3	0.8	55 × 97	T1	0.3	138	E53.H97-251T11	18/FB3
0.047	7200	10800	10800	13.4	15	4.9	20	0.3	0.9	55 × 97	T1	0.3	138	E53.H97-470T10	18/FB3
<b><math>U_N</math> 4000V AC</b>		<b><math>U_{rms}</math> 2800V</b>													
0.1	5000	7500	7500	9.3	15	4.9	20	0.45	1.35	55 × 97	T1	0.3	138	E53.H97-101T10	18/FB3



E53 H/E55  
DC  
600...1100V DC

for latest edition and updates  
check [www.powercapacitors.info](http://www.powercapacitors.info)



**Low-inductance DC-Capacitors**  
Niederinduktive Gleichspannungskondensatoren

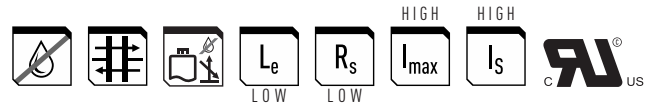

**Standards** ..... IEC 61071, UL810, CSA 22.2 No.190  
optional IEC 61881

**can Gehäuse** ..... plastic Kunststoff (UL94: V0)  
**mounting position Einbaulage**... optional beliebig  
**filling material** ..... solid, based on vegetable oil, non-PCB  
**Füllmittel** ..... ausgehärtet, auf Pflanzenölbasis, PCB-frei  
**Internal protection** ..... none  
**Interne Sicherung** ..... keine  
**fire load Brandlast** ..... 40 MJ/kg

**C<sub>N</sub> tolerance Toleranz** ..... ±10% (optional ±5%)  
**tanδ<sub>0</sub>** ..... 2 × 10<sup>-4</sup>  
**operating temperatures Grenztemperaturen**  
Θ<sub>min</sub> ... Θ<sub>max</sub> ..... -40 ... +85°C  
(E53 H: -25°C)  
Θ<sub>HOTSPOT</sub> ..... ≤ 85°C  
**storing temperature Lagertemperatur** ..... -40 ... +85°C  
**Failure rate Ausfallrate** ..... 50 FIT

(reference interval\_Referenzintervall 100000 h, Θ<sub>HOTSPOT</sub> ≤ 70°C)



C <sub>N</sub> (μF)	U <sub>ripple</sub> (V)	U <sub>S</sub> (V)	U <sub>BB</sub> (V)	R <sub>S</sub> (mΩ)	R <sub>th</sub> (K/W)	I <sub>max</sub> (A)	I <sub>h</sub> (kA)	I <sub>S</sub> (kA)	L <sub>e</sub> (nH)	D <sub>1</sub> × L <sub>1</sub> (mm)	Design Maßbild	m (kg)	L/K (mm)	order no. Bestell-Nr.	pcs_Stk / Box
<b>U<sub>N</sub> 600V DC</b>			<b>U<sub>S</sub> 900V</b>			<b>U<sub>BB</sub> 900V DC</b>									
200	100	900	900	0.75	6.1	60	3.3	9.9	30	85 × 51	H1	0.4	29 / 33	E53.N51-204H10	8/FB6
280	100	900	900	0.85	4.8	60	3.5	10.5	35	85 × 64	H4	0.5	29 / 33	E53.N64-284H40	8/FB4
400	100	900	900	1.1	4.1	60	3.3	10	40	85 × 76	H1	0.5	29 / 33	E53.N76-404H10	8/FB4
400	100	900	900	1.1	4.1	60	3.3	9.9	40	85 × 76	H2	0.5	29 / 33	E53.N76-404H20	8/FB6
1100	100	900	900	0.3	2.3	100	6	19	15	115 × 100	T2	1.4	195	E55.R10-115T22	6/FB8
<b>U<sub>N</sub> 700V DC</b>			<b>U<sub>S</sub> 1050V</b>			<b>U<sub>BB</sub> 1050V DC</b>									
150	160	1050	1050	0.7	6.1	60	2.9	8.7	30	85 × 51	H1	0.4	29 / 33	E53.N51-154H11	8/FB6
200	160	1050	1050	0.92	4.8	60	2.9	8.7	35	85 × 64	H4	0.5	29	E53.N64-204H40	8/FB4
300	160	1050	1050	1.2	4.1	60	2.9	8.7	40	85 × 76	H1	0.5	29 / 33	E53.N76-304H10	8/FB4
400	200	1050	1050	1.2	3.1	60	2.6	7.8	60	85 × 100	H1	0.7	29 / 33	E53.N10-404H10	8/FB2
<b>U<sub>N</sub> 900V DC</b>			<b>U<sub>S</sub> 1350V</b>			<b>U<sub>BB</sub> 1350V DC</b>									
57	200	1350	1350	2.2	8.5	45	0.9	2.7	15	55 × 56	T1	0.2	97	E55.H56-573T10	15/FB6
130	200	1350	1350	1.1	6.1	60	2.7	8	30	85 × 51	H1	0.4	29 / 33	E53.N51-134H10	8/FB6
150	160	1350	1350	1	4.8	60	2.5	7.5	35	85 × 64	H4	0.5	29 / 33	E53.N64-154H41	8/FB4
200	200	1350	1350	0.63	5.2	80	3	9	15	90 × 56	T2	0.5	126	E55.P56-204T21	10/FB2
260	200	1350	1350	1.3	4.1	60	2.7	8.1	40	85 × 76	H2	0.5	29	E53.N76-264H20	8/FB4
250	280	1350	1350	0.35	4.5	100	4	12	15	105 × 56	T2	0.6	141	E55.Q56-254T20	10/FB2
<b>U<sub>N</sub> 1100V DC</b>			<b>U<sub>S</sub> 1650V</b>			<b>U<sub>BB</sub> 1650V DC</b>									
75	200	1650	1650	1	6.1	60	2	6.1	30	85 × 51	H1	0.4	29 / 33	E53.N51-753H10	8/FB6
100	250	1650	1650	0.9	4.8	60	2	6.2	35	85 × 64	H4	0.5	29 / 33	E53.N64-104H40	8/FB4
150	200	1650	1650	1.5	4.1	75	2	6.1	40	85 × 76	H1	0.5	29 / 33	E53.N76-154H11	8/FB4

Other values and dimensions available on request  
Andere Werte und Abmessungen auf Anfrage erhältlich





$C_N$ ( $\mu\text{F}$ )	$U_{\text{ripple}}$ (V)	$U_S$ (V)	$U_{\text{BB}}$ (V)	$R_S$ ( $\text{m}\Omega$ )	$R_{\text{th}}$ (K/W)	$I_{\text{max}}$ (A)	$\hat{I}$ (kA)	$I_S$ (kA)	$L_e$ (nH)	$D_1 * L_1$ (mm)	Design Maßbild	m (kg)	L/K (mm)	order no. Bestell-Nr.	pcs_Stk / Box	
<b><math>U_N</math> 1300V DC</b>		<b><math>U_S</math> 1950V</b>			<b><math>U_{\text{BB}}</math> 1950V DC</b>											
50	300	1950	1950	1.1	6.1	70	1.6	4.8	30	85 × 51	H1	0.4	29 / 33	E53.N51-503H10	8/FB6	
50	400	1950	1950	0.98	6.3	65	2.4	7.2	15	75 × 56	T2	0.3	111	E55.M56-503T20	10/FB2	
90	400	1950	1950	0.55	4.9	80	4.3	13	15	95 × 56	T2	0.5	131	E55.P56-903T20	10/FB2	
97	300	1950	1950	1.3	4.1	60	1.5	4.5	30	85 × 76	H2	0.5	29	E53.N76-973H20	8/FB6	
100	240	1950	1950	1.5	4.1	60	1.6	4.8	40	85 × 76	H1	0.5	29 / 33	E53.N76-104H10	8/FB4	
<b><math>U_N</math> 1500V DC</b>		<b><math>U_S</math> 2250V</b>			<b><math>U_{\text{BB}}</math> 2250V DC</b>											
10	400	1800	1800	2.5	9.9	30	0.4	1.3	15	55 × 48	T1	0.2	89	E55.H48-103T10	15/FB6	
32	280	2100	2100	1.1	6.1	60	1.2	3.6	30	85 × 51	H1	0.4	29 / 33	E53.N51-323H10	8/FB6	
40	350	2325	2325	0.94	6.1	60	1.4	4.2	30	85 × 51	H1	0.4	29 / 33	E53.N51-403H10	8/FB6	
40	350	2250	2250	0.94	6.1	60	1.4	4.2	30	85 × 51	H2	0.4	29 / 33	E53.N51-403H20	8/FB6	
50	280	2250	2250	1.5	4.8	60	1.4	4.2	35	85 × 64	H4	0.5	29 / 33	E53.N64-503H40	8/FB4	
75	280	2250	2250	2	4.1	70	1.4	4.2	40	85 × 76	H1	0.5	29 / 33	E53.N76-753H11	8/FB4	
85	280	2250	2250	1.9	4.1	70	1.6	5	40	85 × 76	H1	0.5	29 / 33	E53.N76-853H10	8/FB4	
100	480	2100	2100	0.34	4.1	100	2.8	8	15	115 × 56	T2	0.8	151	E55.R56-104T20	12/FB9	
<b><math>U_N</math> 1800V DC</b>		<b><math>U_S</math> 2700V</b>			<b><math>U_{\text{BB}}</math> 2700V DC</b>											
22	600	2700	2700	1.5	6.3	40	1.6	4.8	15	75 × 56	T2	0.3	111	E55.M56-223T20	10/FB2	
30	400	2700	2700	0.73	6.1	60	1.3	3.9	30	85 × 51	H1	0.4	29 / 33	E53.N51-303H10	8/FB6	
38	400	2700	2700	2	4.8	55	1.2	4	35	85 × 64	H4	0.5	29 / 33	E53.N64-383H40	8/FB4	
60	400	2700	2700	2.1	4.1	50	1.3	3.9	40	85 × 76	H1	0.5	29 / 33	E53.N76-603H10	8/FB4	
<b><math>U_N</math> 2000V DC</b>		<b><math>U_S</math> 3000V</b>			<b><math>U_{\text{BB}}</math> 3000V DC</b>											
12	300	3000	3000	2.1	6.3	46	0.4	1.3	15	75 × 56	T2	0.3	111	E55.M56-123T20	10/FB2	
30	400	3000	3000	1.3	4.8	55	1.1	3.3	35	85 × 64	H4	0.5	29 / 33	E53.N64-303H40	8/FB4	
43	400	3000	3000	1.8	4.1	50	1	3	40	85 × 76	H1	0.5	29 / 33	E53.N76-433H10	8/FB4	
50	650	3000	3000	0.55	4.1	100	4.1	12.3	15	115 × 56	T2	0.8	151	E55.R56-503T20	12/FB9	
<b><math>U_N</math> 2200V DC</b>		<b><math>U_S</math> 3300V</b>			<b><math>U_{\text{BB}}</math> 3300V DC</b>											
35	600	3300	3300	2	4.1	50	0.94	2.82	40	85 × 76	H1	0.5	29	E53.N76-353H10	8/FB4	
<b><math>U_N</math> 2800V DC</b>		<b><math>U_S</math> 4200V</b>			<b><math>U_{\text{BB}}</math> 4200V DC</b>											
13	800	3600	3600	1.6	4.9	80	0.81	2.43	15	95 × 56	T2	0.5	131	E55.P56-133T20	10/FB2	
18	900	4200	4200	0.6	4.5	90	4.5	13.5	15	105 × 56	T2	0.6	141	E55.Q56-183T20	10/FB2	





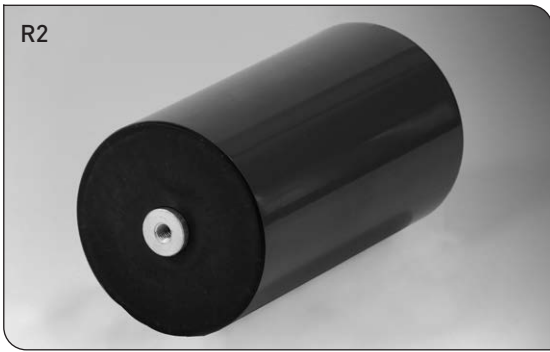

R2



Design R2

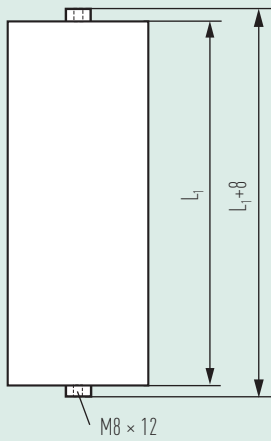

**CAPACITORS WITH A CAN DIAMETER OF 64, 90, 116, 140 mm**

**Can material** ..... plastic can, filled with solid PUR resin  
**Terminals** ..... brass, axial thread M8 × 12 mm  
**I<sub>max</sub> (Terminals)** ..... 100 A  
**Degree of protection** ..... IP 00  
**K/L** ..... (L<sub>1</sub> + D<sub>1</sub> - 20 mm)  
**Humidity class** ..... T1 (IEC 62498-1)

**KONDENSATOREN MIT GEHÄUSEDURCHMESSER 64, 90, 116, 140 mm**

**Gehäusematerial** ..... Kunststoff, gefüllt mit ausgehärtetem Polyurethanharz  
**Anschlüsse** ..... Messing, axiales Schraubgewinde M8 × 12 mm  
**I<sub>max</sub> (Anschlüsse)** ..... 100 A  
**Schutzgrad** ..... IP 00  
**K/L** ..... (L<sub>1</sub> + D<sub>1</sub> - 20 mm)  
**Feuchtekategorie** ..... T1 (IEC 62498-1)



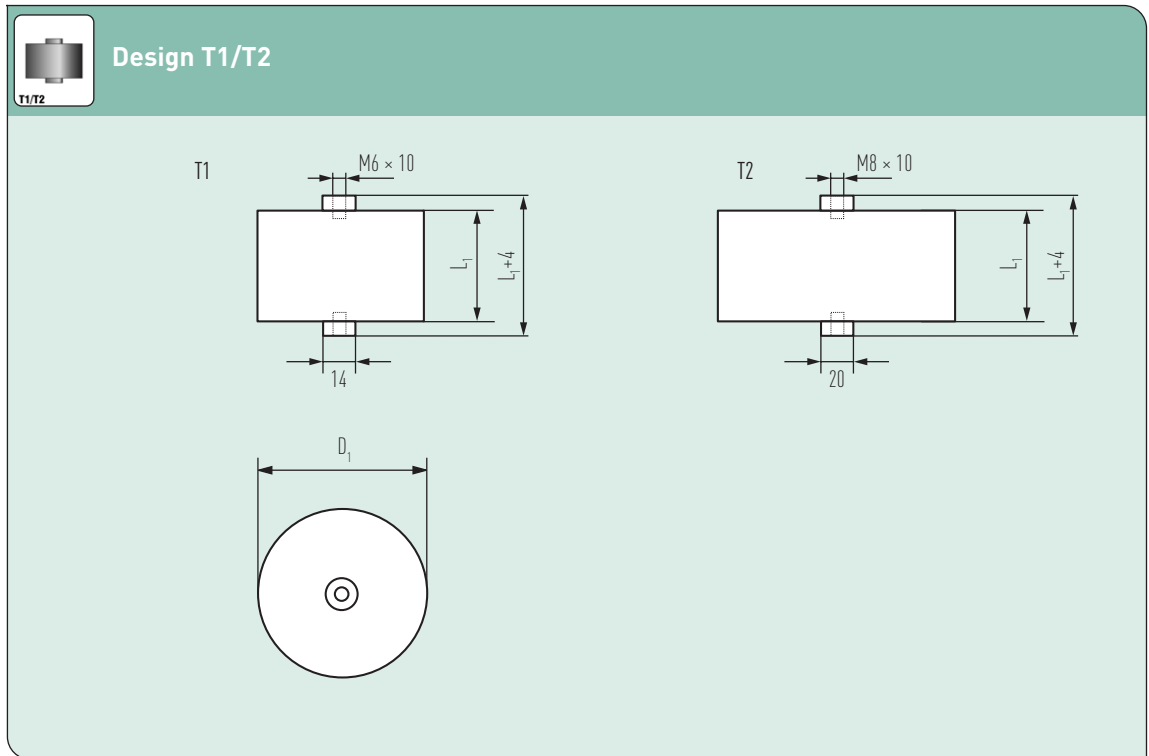
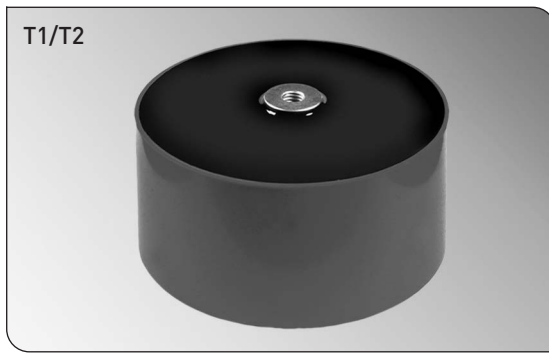

**T1 CAPACITORS WITH A CAN DIAMETER OF 55...60 mm**

**T2 CAPACITORS WITH A CAN DIAMETER OF 75...115 mm**

**Can material** ..... plastic can, filled with solid PUR resin

**Terminals** ..... brass, axial thread

**T1** ..... M6 × 10 mm

**T2** ..... M8 × 10 mm

**I<sub>max</sub> (Terminals)**

**T1** ..... 60 A

**T2** ..... 100 A

**Degree of protection** ..... IP 00

**K/L** ..... see data charts

**Humidity class** ..... G, T3 (IEC 62498-1)

**T1 KONDENSATOREN MIT GEHÄUSEDURCHMESSER 55...60 mm**

**T2 KONDENSATOREN MIT GEHÄUSEDURCHMESSER 75...115 mm**

**Gehäusematerial** ..... Kunststoff, gefüllt mit ausgehärtetem Polyurethanharz

**Anschlüsse** ..... Messing, axiales Schraubgewinde

**T1** ..... M6 × 10 mm

**T2** ..... M8 × 10 mm

**I<sub>max</sub> (Anschlüsse)**

**T1** ..... 60 A

**T2** ..... 100 A

**Schutzgrad** ..... IP 00

**K/L** ..... siehe Datentabellen

**Feuchteklasse** ..... G, T3 (IEC 62498-1)

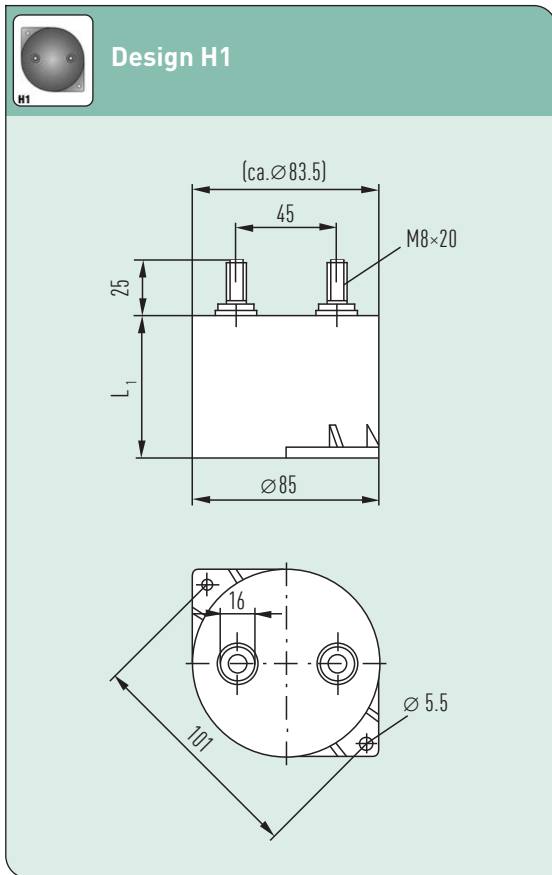

#### H1 CAPACITORS WITH A CAN DIAMETER OF 85 mm

**Can material** ..... plastic can, filled with solid PUR resin  
**Fixing** ..... lateral mounting brackets  
**Terminals** ..... brass, threaded studs M8 × 20 mm  
**I<sub>max</sub> (Terminals)** ..... 100 A  
**Degree of protection** ..... IP 00  
**K/L** ..... see data charts  
**Humidity class** ..... T1 (IEC 62498-1)

#### H1 KONDENSATOREN MIT GEHÄUSEDURCHMESSER 85 mm

**Gehäusematerial** ..... Kunststoff, gefüllt mit ausgehärtetem Polyurethanharz  
**Befestigung** ..... seitliche Montagelaschen  
**Anschlüsse** ..... Messing, Gewindebolzen M8 × 20 mm  
**I<sub>max</sub> (Anschlüsse)** ..... 100 A  
**Schutzgrad** ..... IP 00  
**K/L** ..... siehe Datentabellen  
**Feuchtekategorie** ..... T1 (IEC 62498-1)



## Important Remarks

### General

Our catalogues outline the typical technical and mechanical characteristics of the listed capacitors. The stated values are based on reference type tests, as well as empirical and experimental experience. The real values of individual capacitors may differ within the stated, or commonly known, tolerances. Any information given in this catalogue therefore describes the components in general terms and does not constitute any guarantee of individual technical values.

It is the responsibility of the user to ensure by dedicated tests the suitability and safety of operation of our components under the conditions of his application. This also applies to any accessories offered by ELECTRONICON.

### Safety

Safe operation of the capacitors can be expected only if all safety recommendations as well as electrical and thermal specifications as stated on the label, in the data sheets, catalogues and the accompanying mounting instructions are strictly observed, and recommended safety devices are used as intended. Please consider the "General Safety Recommendations" of the power capacitor manufacturers organized in the German ZVEI ([www.electronicon.com/en/zvei](http://www.electronicon.com/en/zvei)).

The capacitors shall only be used for the intended application. ELECTRONICON will not indemnify or be responsible for any kind of damages to persons or property due to the improper application of any capacitors purchased from ELECTRONICON or its distributors.

Mind that electrical or mechanical misapplication of capacitors can become hazardous. Misapplied capacitors can explode or catch fire and cause bodily injury or property damage due to the expulsion of material or metal fragments.

Please consult the detailed instructions for mounting and application stated in our brochure „Application Notes“ and on the ELECTRONICON website: [www.electronicon.com/en/an](http://www.electronicon.com/en/an)

If in doubt about how to connect, operate, or discharge a capacitor, consult ELECTRONICON engineering or our distributors.

### Mounting And Cooling

The useful life of a capacitor may be reduced dramatically if exposed to excessive heat. Typically an increase in the ambient temperature of 7°C will halve the expected life of the capacitor. Make sure to obey the permitted operating temperatures.

To avoid overheating the capacitors must be allowed to cool unhindered and should be shielded from external heat sources. We recommend forced ventilation for all filter applications with reactors. Give approx. 20 mm clearance around capacitors for natural or forced ventilation, and do not place them directly above or next to heat sources such as detuning or tuning reactors, bus bars, etc.

## Wichtige Hinweise

### Allgemeines

Unsere Kataloge beschreiben die typischen technischen und mechanischen Eigenschaften der aufgeführten Kondensatoren. Die angegebenen Werte basieren auf Referenztypprüfungen sowie empirischen und experimentellen Erfahrungswerten. Die tatsächlichen Werte einzelner Kondensatoren können innerhalb der angegebenen bzw. allgemein bekannter Toleranzen abweichen. Alle Angaben in diesem Katalog beschreiben daher die Komponenten im Allgemeinen und stellen keine Garantie für individuelle technische Werte dar.

Es liegt in der Verantwortung des Anwenders, durch gezielte Prüfungen die Eignung und Betriebssicherheit unserer Komponenten unter den konkreten Betriebsbedingungen seiner Anwendung sicherzustellen. Dies gilt ebenso für gegebenenfalls von ELECTRONICON angebotene Zubehörteile.

### Sicherheit

Ein sicherer Betrieb der Kondensatoren ist nur zu erwarten, wenn alle Sicherheitsempfehlungen sowie elektrische und thermische Spezifikationen entsprechend Etikett, Datenblättern, Katalogen und beiliegenden Montageanleitungen eingehalten und die empfohlenen Sicherheitseinrichtungen bestimmungsgemäß verwendet werden. Bitte beachten Sie die „Allgemeinen Sicherheitsempfehlungen“ der im deutschen ZVEI organisierten Hersteller von Leistungskondensatoren ([www.electronicon.com/en/zvei](http://www.electronicon.com/en/zvei)).

Die Kondensatoren dürfen ausschließlich für ihren Bestimmungszweck verwendet werden. ELECTRONICON übernimmt keine Verantwortung oder Haftung für Schäden an Personen oder Eigentum, welche aus unsachgemäßer Anwendung von Kondensatoren herrührt.

Elektrisch oder mechanisch fehlerhaft eingesetzte Kondensatoren können explodieren oder Feuer fangen. Austretende Materialien bzw. Metallteile können gesundheitliche und materielle Schäden verursachen.

Bitte beachten Sie die detaillierten Anweisungen in unserer Broschüre „Anwendungshinweise“ sowie auf der Webseite von ELECTRONICON: [www.electronicon.com/an](http://www.electronicon.com/an)

Bitte konsultieren Sie das Fachpersonal oder unsere Distributoren zu Fragen bezüglich Anschluss, Verwendung oder Entladung von Kondensatoren.

### Montage und Kühlung

Die Lebensdauer eines Kondensators kann durch übermäßige Wärmeeinwirkung erheblich verringert werden. Im allgemeinen führt eine Erhöhung der Umgebungstemperatur um 7°C zu einer Verringerung der Lebensdauer des Kondensators um 50 %. Halten Sie die zugelassenen Betriebstemperaturen ein.

Um Überhitzung zu vermeiden, muß gewährleistet sein, daß die Kondensatoren auftretende Verlustwärme ungehindert abführen können und vor fremden Wärmequellen abgeschirmt werden. Insbesondere in Filtern ist in jedem Falle eine Zwangslüftung zu empfehlen. Zwischen und um Kondensatoren sollten etwa 20 mm Platz für natürliche oder Zwangslüftung belassen werden. Bringen Sie den Kondensator nie direkt neben oder über Wärmequellen, wie Drosseln u. ä. an.



### Protection against Overvoltages And Short Circuits: Self-Healing Dielectric

All dielectric structures used in our power capacitors are „selfhealing“: In the event of a voltage breakdown the metal layers around the breakdown channel are evaporated by the temperature of the electric arc that forms between the electrodes. They are removed within a few microseconds and pushed apart by the pressure generated in the centre of the breakdown spot. An insulation area is formed which is reliably resistive and voltage proof for all operating requirements of the capacitor. The capacitor remains fully functional during and after the breakdown.

For voltages within the permitted testing and operating limits the capacitors are short-circuit- and overvoltage-proof. They are also proof against external short circuits as far as the resulting surge discharges do not exceed the specified surge current limits.

### Failure Rate

The failure probability of a component is a statistical value which is described by a log-normal distribution:

$$N = N_0 \times e^{-\lambda t}$$

$\lambda$  is the failure rate, which alternatively is also stated as the so-called FIT-rate (FIT = Failures In Time =  $\lambda \times 10^9$ ).

The failure rate is very closely linked with operating temperature and operating voltage of the capacitor. The FIT rates stated in this catalogue are related to the capacitor's rated voltage and a dielectric temperature (= HOTSPOT temperature) of 70°C.

The simultaneous operation of capacitors at highest permissible voltage and operating temperature should be avoided; otherwise, failure rates may increase beyond reasonable technical reliability.

The standard reference period for the failure rate statement is 100.000 hours. Please note that FIT rates can be altered or improved by technical adjustments. Please contact us for details.

The following diagrams demonstrate the correlation between FIT rate, operating voltages and operating temperatures.

### Schutz gegen Überspannungen und Kurzschlüsse: Selbsteheilendes Dielektrikum

Alle in unseren Leistungskondensatoren eingesetzten dielektrischen Strukturen sind selbsteheilend. Im Falle eines Kurzschlusses (Spannungsdurchschlag) verdampfen die Metallbeläge um den Durchschlagpunkt herum infolge des Lichtbogens, der sich zwischen den Elektroden bildet. Binnen Mikrosekunden wird der Metaldampf vom Zentrum des Durchschlages weggedrückt. Auf diese Weise bildet sich eine isolierende belagfreie Zone um den Durchschlagpunkt. Der Kondensator bleibt während und nach dem Durchschlag voll funktionsfähig.

Für Spannungen innerhalb der zugelassenen Test- und Betriebsbedingungen sind die Kondensatoren kurzschluss- und überspannungssicher. Sie sind außerdem sicher gegen äußere Kurzschlüsse, sofern bei den dabei entstehenden Stoßentladungen die zugelassenen Stoßströme nicht überschritten werden.

### Ausfallrate

Die Ausfallwahrscheinlichkeit eines Bauelements ist eine statistische Größe, die mit Hilfe einer Normalverteilung beschrieben wird. Es gilt:

$N$  = number of functional components after period  $t$

Anzahl der nach der Zeit  $t$  intakten Bauelemente

$N_0$  = total number of components at time  $t = 0$

Gesamtzahl der Bauelemente zum Zeitpunkt  $t = 0$

$\lambda$  = failure rate Ausfallrate

Dabei ist  $\lambda$  die Ausfallrate, die alternativ auch als FIT-Rate angegeben wird (FIT =  $\lambda \times 10^9$ )

Die Ausfallrate ist stark abhängig von der Temperatur und der Betriebsfeldstärke. Die FIT-Raten im Katalogsortiment beziehen sich auf 70°C Dielektrikumtemperatur (=Hotspot-Temperatur) und die Nennspannung des Kondensators.

Der Betrieb von Kondensatoren mit der höchsten zulässigen Spannung und der höchsten zulässigen Betriebstemperatur sollte vermieden werden, andernfalls können die Ausfallraten so hoch werden, dass keine technisch sinnvollen Zuverlässigkeiten mehr gewährleistet sind.

Der Wert für die Ausfallrate bezieht sich auf einen Referenzzeitraum von 100.000h. FIT-Raten können durch technische Anpassung der Kondensatoren beeinflusst und verbessert werden. Auskünfte hierzu erteilen wir auf Anfrage.

Die nachstehenden Kurvendiagramme machen den Zusammenhang von FIT-Rate, Betriebsspannung und Betriebstemperatur deutlich.



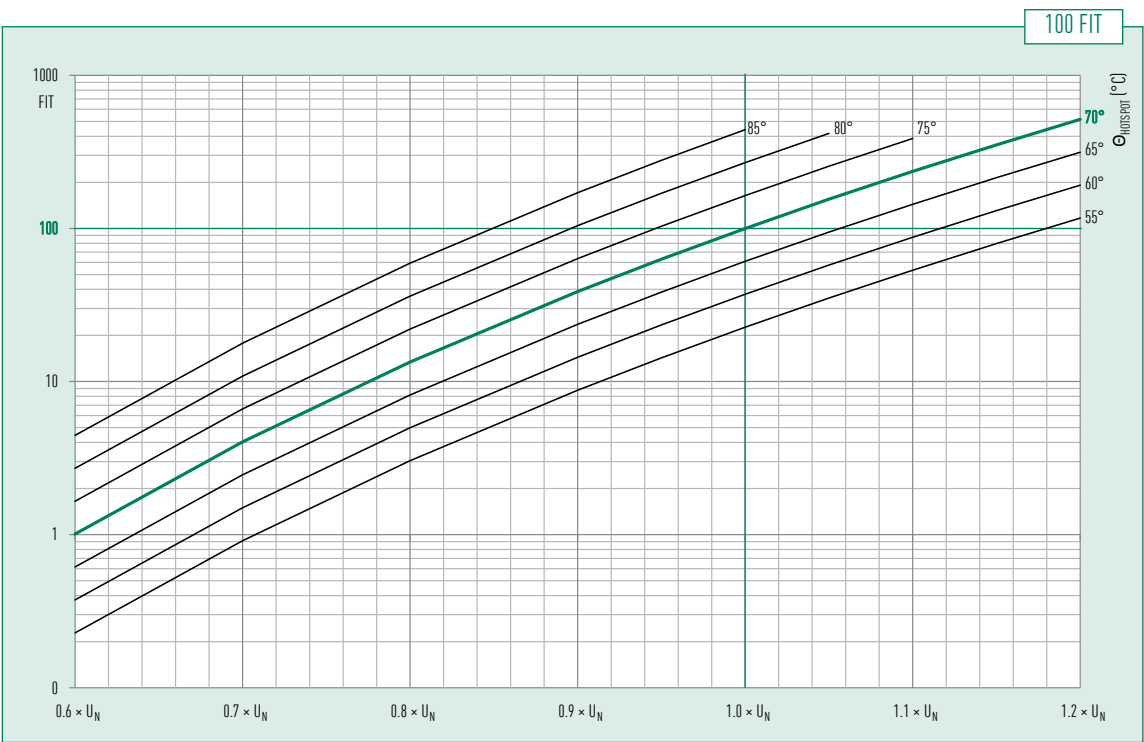
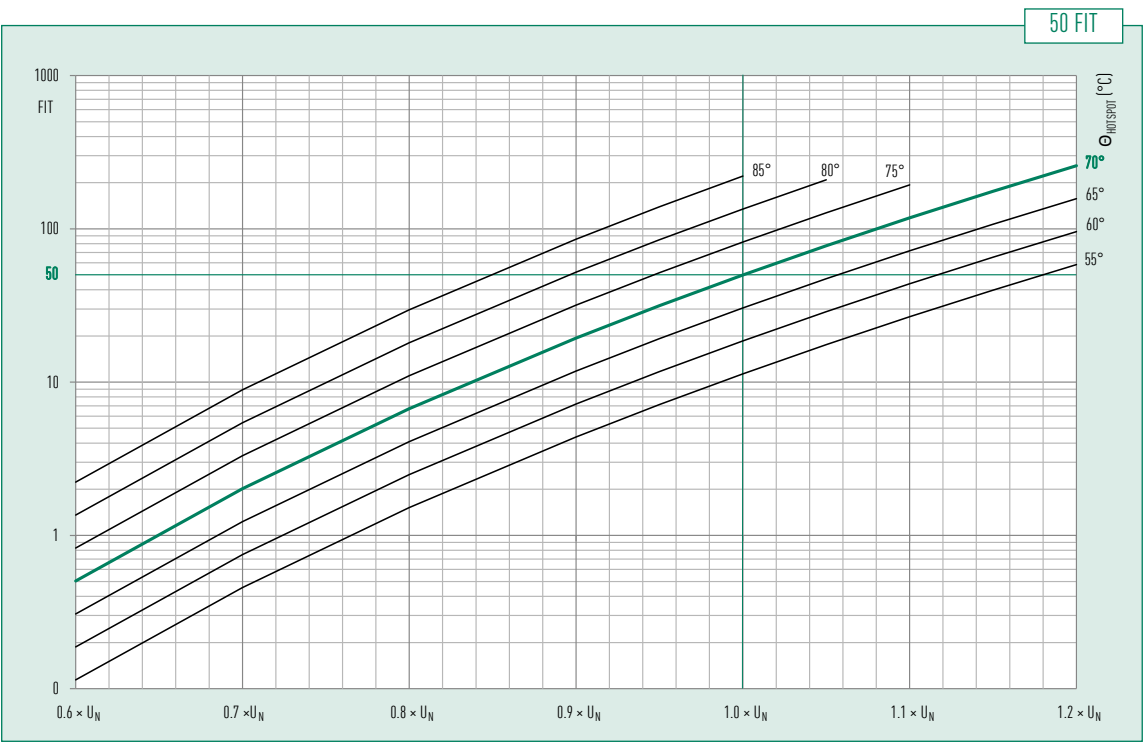



### Limited Warranty

All our products are designed, manufactured, and tested with the highest care and workmanship. The satisfaction of our customers is our highest goal. We therefore warrant remedying any defect in the goods resulting from faulty design, materials or workmanship, which appears within 2 years from the date of sale, unless agreed otherwise.

This warranty does not cover defects due to improper use of the goods or operation at conditions exceeding the rated values stated in the catalogue or special data sheet. Nor does it cover defects due to faulty maintenance or incorrect installation, alterations or faulty repairs undertaken by the Buyer. Finally the warranty does not cover normal wear and tear or deterioration.

See our „General Conditions“ for details on Warranty and Product liability.

### Gewährleistung

Alle unsere Erzeugnisse werden mit höchster Sorgfalt und Fachkenntnis entwickelt, hergestellt und geprüft. Die Zufriedenheit unserer Kunden ist unser höchstes Ziel. Wir verpflichten uns daher, sofern nicht anders vereinbart, jeden innerhalb von 2 Jahren ab Verkaufsdatum auftretenden Mangel an unseren Erzeugnissen zu beseitigen, welcher aus Fehlern in Design, Material oder Herstellung herrührt.

Diese Gewährleistung erstreckt sich nicht auf Defekte infolge unsachgemäßer Anwendung oder Betrieb außerhalb der nach Katalog oder Datenblatt zulässigen Einsatzbedingungen. Sie erfaßt ebensowenig Schäden aufgrund fehlerhafter Wartung, unsachgemäßer Montage, Änderungen oder unsachgemäßer Reparaturen durch den Käufer bzw. Anwender. Diese Gewährleistung betrifft auch nicht normale Abnutzung und Verschleiß.

Siehe unsere „Allgemeinen Geschäftsbedingungen“ für Details zu Gewährleistung und Produkthaftung.

Find more information and detailed instructions in our „Application Notes“ and on [www.electronicon.com](http://www.electronicon.com)  
Mehr Informationen und ausführliche Anweisungen finden Sie in unseren „Anwendungshinweisen“ und unter [www.electronicon.com](http://www.electronicon.com)

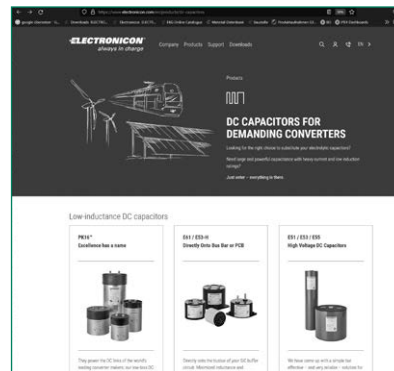
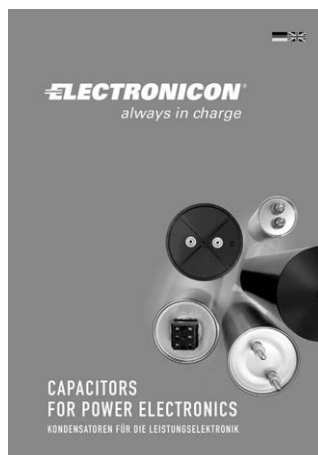

NOTES  
NOTIZEN

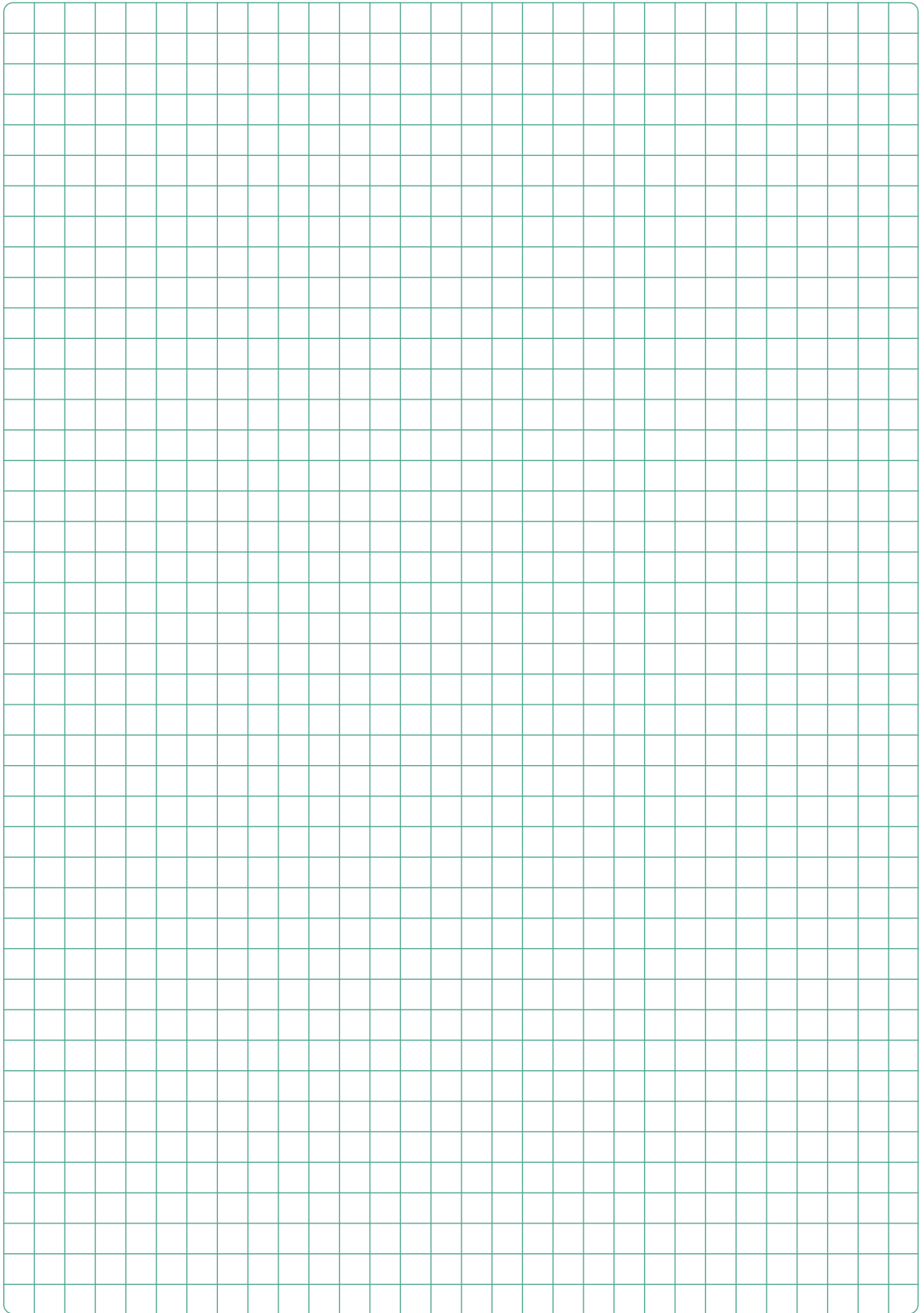

NOTES\_NOTIZEN



www.electronicon.com Issue: 04/2022

**E56 / E57 / E59 / SR17™** AC AND DC CAPACITORS WITH LARGE CAPACITANCES

STANDARD OR SPECIAL – YOUR CHOICE

**ELECTRONICON**  
Always in charge

www.electronicon.com Issue: 04/2022

**PK16 GA85 E61** – HIGH DENSITY DC FILM CAPACITORS

THE IDEAL CHOICE FOR YOUR DC LINK

**ELECTRONICON**  
Always in charge

www.electronicon.com Issue: 04/2022

**E51 / E53 / E55** AC FILM CAPACITORS

HIGH VOLTAGES, HEAVY CURRENTS, AND LOW INDUCTANCES

**ELECTRONICON**  
Always in charge

## CAPACITORS FOR POWER ELECTRONICS

www.electronicon.com Issue: 04/2022

**PKmind™** DC CAPACITORS WITH ULTRA LOW SELF-INDUCTANCE

INDUCTANCE AS LOW AS IT CAN GET

**ELECTRONICON**  
Always in charge

www.electronicon.com Issue: 3/2022

**E62-3ph and 3HF** HEAVY DUTY THREE PHASE AC FILTER CAPACITORS

HIGH-END FOR THE HEART OF YOUR AC FILTER

**ELECTRONICON**  
Always in charge

www.electronicon.com Issue: 04/2022

**E62 and E64** HEAVY DUTY AC CAPACITORS

THE PERFECT CHOICE FOR YOUR AC/DC APPLICATION

**ELECTRONICON**  
Always in charge

## COMPONENTS FOR POWER FACTOR CORRECTION

www.electronicon.com Issue: 04/2022

**GA85 Mesis®** DC CAPACITORS WITH PROTECTION DEVICE

WELL-PROTECTED AND WITH EXTREMELY LOW INDUCTANCE

**ELECTRONICON**  
Always in charge

www.electronicon.com Issue: 2021

DC CAPACITORS

HERMETICAL CASE WITH AUTONOMOUS SAFETY MECHANISM

**ELECTRONICON**  
Always in charge

www.electronicon.com Issue: 04/2022

**MSD™ FKD-MV™ DSC™** MEDIUM VOLTAGE CAPACITORS AND REACTORS

THE ECO-FRIENDLY ALTERNATIVE

**ELECTRONICON**  
Always in charge

www.electronicon.com Issue: 04/2022

KEY COMPONENTS FOR POWER FACTOR CORRECTION IN SMD SYSTEMS

FACTORY MATCHED TO OPERATE IN PERFECT HARMONY

**ELECTRONICON**  
Always in charge

www.electronicon.com Issue: 04/2022

**MSD™ FKD-MV™ DSC™** MEDIUM VOLTAGE CAPACITORS AND REACTORS

THE ECO-FRIENDLY ALTERNATIVE

**ELECTRONICON**  
Always in charge

www.electronicon.com Issue: 04/2022

**GA85 Mesis®** DC CAPACITORS WITH PROTECTION DEVICE

WELL-PROTECTED AND WITH EXTREMELY LOW INDUCTANCE

**ELECTRONICON**  
Always in charge

www.electronicon.com Issue: 04/2022

**MSD™ FKD-MV™ DSC™** MEDIUM VOLTAGE CAPACITORS AND REACTORS

THE ECO-FRIENDLY ALTERNATIVE

**ELECTRONICON**  
Always in charge

## EXCELLENT EXPERIENCE IN CAPACITOR MAKING FOR OVER 80 YEARS

Gera has been a centre of capacitor making since 1938. ELECTRONICON Kondensatoren GmbH which emerged from previous RFT/VEB ELEKTRONIK Gera in 1992, has become one of Europe's leading capacitor manufacturers supplying customers worldwide and being an open and competent partner for manufacturers and users of power factor correction as well as industrial applications of power electronics, generation and transmission of green energy, traction, a.m.o. . Regular investments in advanced and environmentally sound technologies guarantee the highest levels in manufacture and quality to modern standards which are approved and monitored by leading certification authorities.

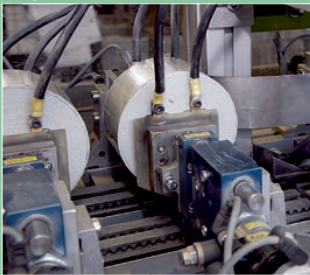
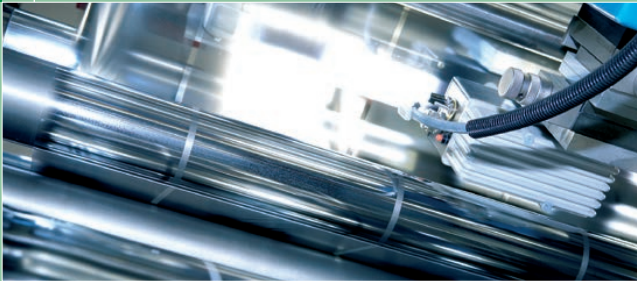

In today's globalised competition, we distinguish ourselves by

- Absolute reliability and safety of our products
- Close co-operation between manufacturer and client to meet both technical and commercial requirements
- Improvement and development of our technical expertise in capacitor design and manufacture, as well as film coating, with special attention paid to the MKPg-technology
- Early identification and incorporation of new trends and methods in the manufacturing of capacitors
- Flexibility and punctual fulfilment of our commercial obligations

Our experienced development engineers are competent and responsible for both implementing the latest technical trends applicable to our products and ensuring that our products adapt to the challenges of traditional and new markets. The close and intense co-operation between the departments of Marketing & Sales, Research & Development, and Production has become the keystone of our success. ELECTRONICON constantly strives for similarly close and interactive relationships with her sales partners and direct customers at home and abroad, so that we are not just one of many suppliers, but your preferred partner for ideas and solutions.

# ELECTRONICON®

Germany • 07549 Gera • Keplerstrasse 2  
Fon +49 365 / 734 61 00 • Fax +49 365 / 734 61 10  
E-Mail: [sales@electronicon.com](mailto:sales@electronicon.com), [www.electronicon.com](http://www.electronicon.com)

