

QxxxxLTx Series

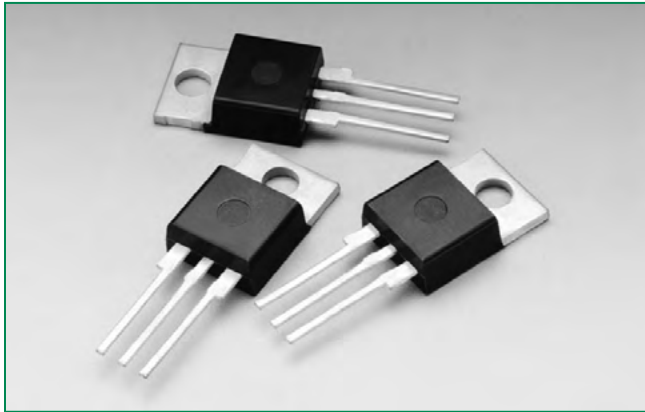

Agency Recognitions

Agency	Agency File Number
	L Package : E71639

Schematic Symbol

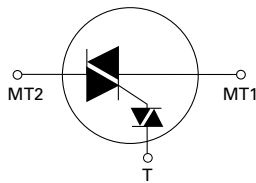

Main Features

Symbol	Value	Unit
$I_{T(RMS)}$	4 to 15	A
V_{DRM}/V_{RRM}	400 to 600	V
DIAC V_{BO}	33 to 43	V

Description

The Quadrac is an internally triggered Triac designed for AC switching and phase control applications. It is a Triac and DIAC in a single package, which saves user expense by eliminating the need for separate Triac and DIAC components.

Standard type components normally operate in Quadrants I & III triggered from AC line.

Alternistor type Quadracs are used in circuits requiring high dv/dt capability.

Features & Benefits

- RoHS Compliant
- Glass – passivated junctions
- Voltage capability up to 600 V
- Surge capability up to 200 A

Applications

Excellent for AC switching and phase control applications such as lighting and heating. Typical applications are AC solid-state switches, light dimmers, power tools, home/ brown goods and white goods appliances.

Alternistor Quadracs (no snubber required) are used in applications with extremely inductive loads requiring highest commutation performance.

Internally constructed isolated package is offered for ease of heat sinking with highest isolation voltage.

Absolute Maximum Ratings

Symbol	Parameter	Value					Unit	
		Qxx04LT	Qxx06LT / Qxx06LTH	Qxx08LT / Qxx08LTH	Qxx10LT / Qxx10LTH	Qxx15LT / Qxx15LTH		
$I_{T(RMS)}$	RMS forward current	Qxx04LT: $T_C = 95^\circ\text{C}$ Qxx06LT/Qxx08LT/Qxx10LT: $T_C = 90^\circ\text{C}$ Qxx15LT: $T_C = 80^\circ\text{C}$					A	
I_{TSM}	Peak non-repetitive surge current	single half cycle; $f = 50\text{Hz}$; T_J (initial) = 25°C	46	65	83	100	167	A
		single half cycle; $f = 60\text{Hz}$; T_J (initial) = 25°C	55	80	100	120	200	
I^2t	I^2t value for fusing	$t_p = 8.3\text{ms}$	12.5	26.5	41	60	166	A ² s
di/dt	Critical rate-of-rise of on-state current	$f = 60\text{Hz}$; $T_J = 125^\circ\text{C}$	50	70			100	A/ μs
I_{GM}	Peak gate current	$T_J = 125^\circ\text{C}$	1.5					A
T_{stg}	Storage temperature range		-40 to 150					$^\circ\text{C}$
T_J	Operating junction temperature range		-40 to 125					$^\circ\text{C}$

Note: xx = voltage

Electrical Characteristics ($T_J = 25^\circ\text{C}$, unless otherwise specified) – Standard Quadrac

Symbol	Test Conditions		Value					Unit	
			Qxx04LT	Qxx06LT	Qxx08LT	Qxx10LT	Qxx15LT		
I_H	$I_T = 200\text{mA}$ (initial)	MAX.	40	50	60	60	70	mA	
dv/dt	$V_D = V_{DRM}$; gate open; $T_J = 100^\circ\text{C}$	MIN.	400V	75	150	175	200	300	V/ μs
			600V	50	125	150	175	200	
	$V_D = V_{DRM}$; gate open; $T_J = 125^\circ\text{C}$	MIN.	400V	50	100	120	150	200	
			600V	50	85	100	120	150	
$dv/dt(c)$	$di/dt(c) = 0.54 \times I_{T(RMS)} / \text{ms}$; $T_J = 125^\circ\text{C}$	MIN.	3	4				V/ μs	
t_{gt}	(note 1)	TYP.	3					μs	

 (1) Reference test circuit in figure 10 and waveform in figure 11; $C_T = 0.1\mu\text{F}$ with 0.1 μs rise time.

Note: xx = voltage

Electrical Characteristics ($T_J = 25^\circ\text{C}$, unless otherwise specified) – Alternistor Quadrac

Symbol	Test Conditions		Value				Unit	
			Qxx06LTH	Qxx08LTH	Qxx10LTH	Qxx15LTH		
I_H	$I_T = 20\text{mA}$ (initial)	MAX.	50	50	60	70	mA	
dv/dt	$V_D = V_{DRM}$; gate open; $T_J = 100^\circ\text{C}$	MIN.	400V	575		925		V/ μs
			600V	425		775		
	$V_D = V_{DRM}$; gate open; $T_J = 125^\circ\text{C}$	MIN.	400V	450		700		
			600V	350		600		
$dv/dt(c)$	$di/dt(c) = 0.54 \times I_{T(RMS)} / \text{ms}$; $T_J = 125^\circ\text{C}$	MIN.	25		30		V/ μs	
t_{gt}	(note 1)	TYP.	3				μs	

 (1) Reference test circuit in figure 10 and waveform in figure 11; $C_T = 0.1\mu\text{F}$ with 0.1 μs rise time.

Note: xx = voltage

QxxxxLTx Series

Trigger DIAC Specifications

Symbol	Test Conditions		Value	Unit
ΔV_{BO}	Breakover Voltage Symmetry	MAX.	3	V
V_{BO}	Breakover Voltage, forward and reverse	MIN.	33	V
		MAX.	43	
$[\Delta V_{\pm}]$	Dynamic Breakback Voltage, forward and reverse (note 1)	MIN.	5	V
I_{BO}	Peak Breakover Current	MAX.	25	μA
C_T	Trigger Firing Capacitance	MAX.	0.1	μF

(1) Reference test circuit in figure 10 and waveform in figure 11.

Static Characteristics

Symbol	Test Conditions		Value	Unit
V_{TM}	$I_T = 1.41 \times I_{T(rms)}$ A; $t_p = 380\mu s$	MAX.	1.6	V
I_{DRM} / I_{RRM}	V_{DRM} / V_{RRM}	$T_J = 25^\circ C$	MAX.	10
		$T_J = 100^\circ C$		500
		$T_J = 125^\circ C$		2000

Thermal Resistances

Symbol	Parameter		Value	Unit
$R_{\theta(JC)}$	Junction to case (AC)	Qxx04LT	3.6	$^\circ C/W$
		Qxx06LT / Qxx06LTH	3.3	
		Qxx08LT / Qxx08LTH	2.8	
		Qxx10LT / Qxx10LTH	2.6	
		Qxx15LT / Qxx15LTH	2.1	
$R_{\theta(J-A)}$	Junction to ambient		50	$^\circ C/W$

Note : xx = voltage

Figure 1: Normalized DC Holding Current vs. Junction Temperature

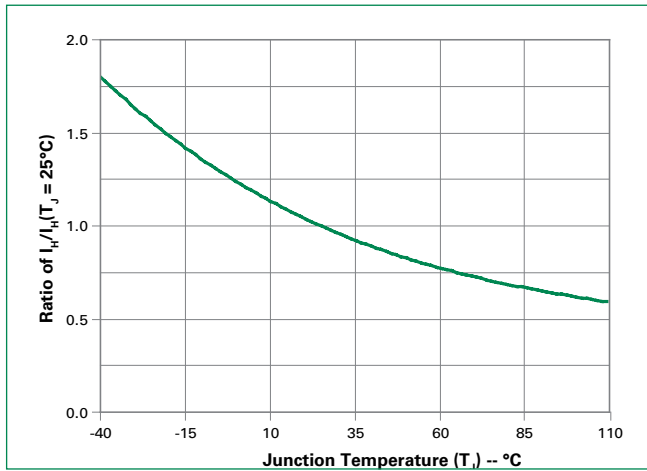

Figure 2: On-State Current vs. On-State Voltage (Typical) (4A)

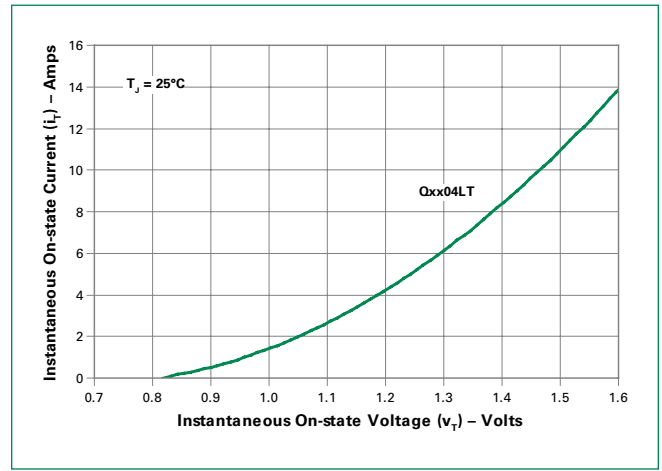

Figure 3: On-State Current vs. On-State Voltage (Typical) (6A to 15A)

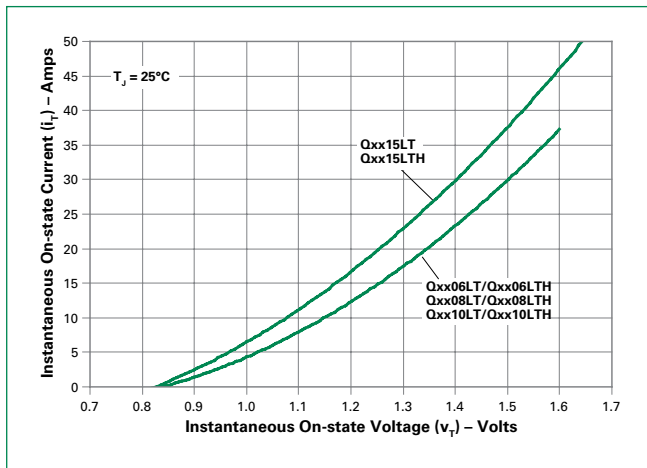

Figure 4: Power Dissipation vs. RMS On-State Current (Typical) (4A)

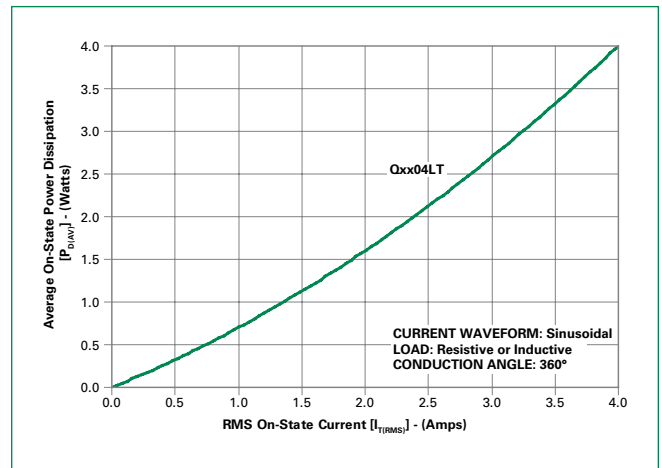

Figure 5: Power Dissipation vs. RMS On-State Current (Typical) (6A to 15A)

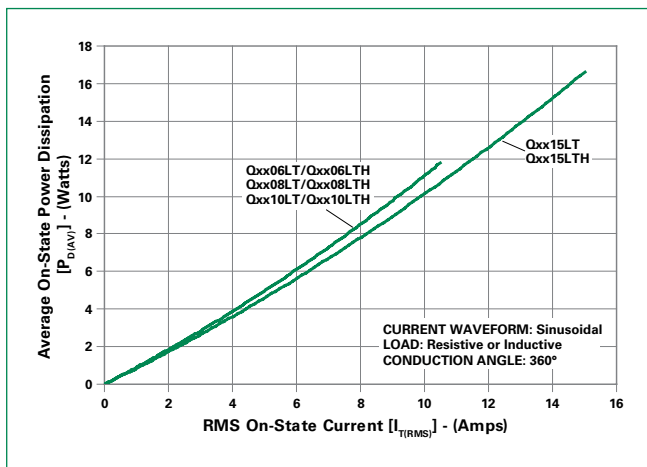

Figure 6: Maximum Allowable Case Temperature vs. RMS On-State Current

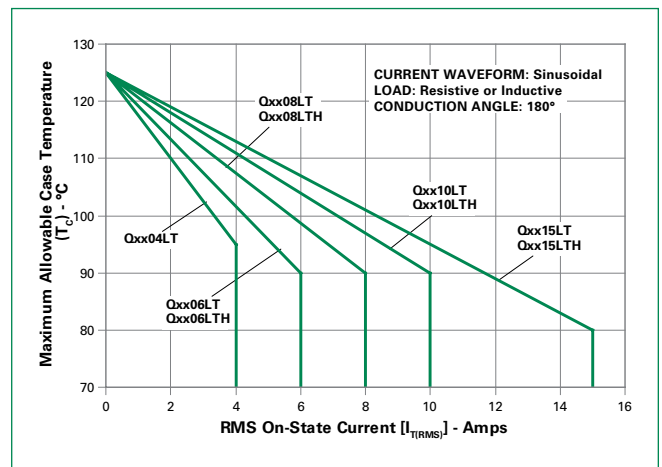
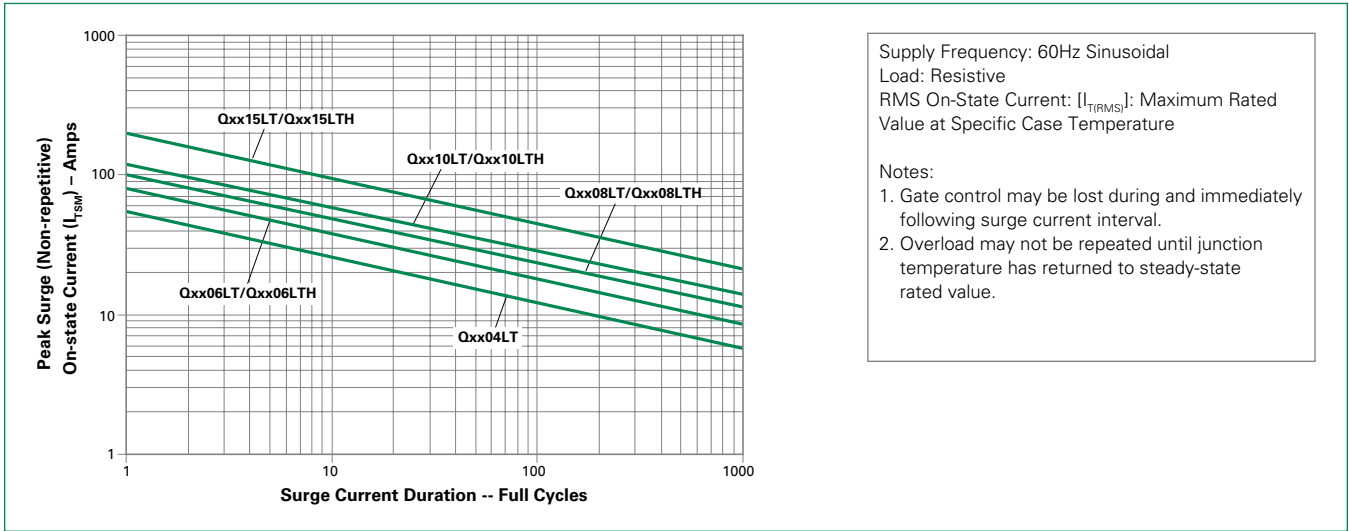

Figure 7: Surge Peak On-State Current vs. Number of Cycles



Note: xx = voltage

Figure 8: DIAC V_{BO} Change vs. Junction Temperature

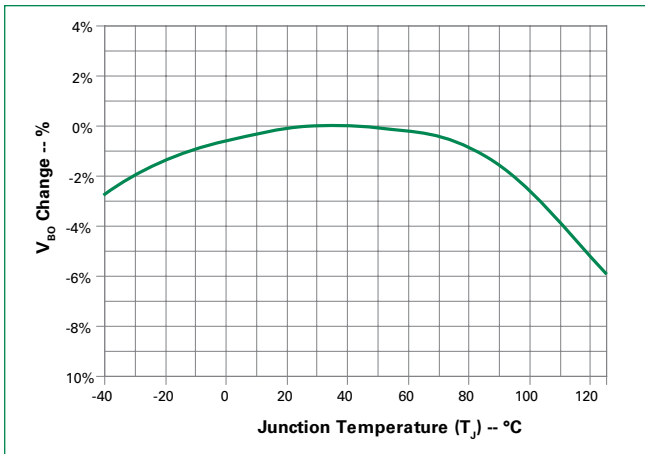

Figure 9: Test Circuit

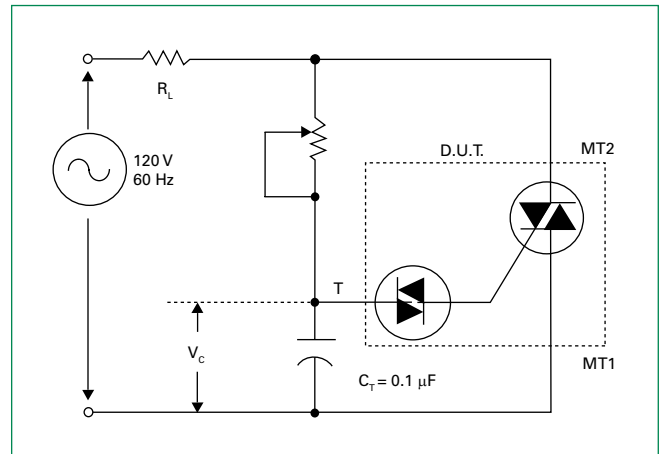

Figure 10: Test Circuit Waveform

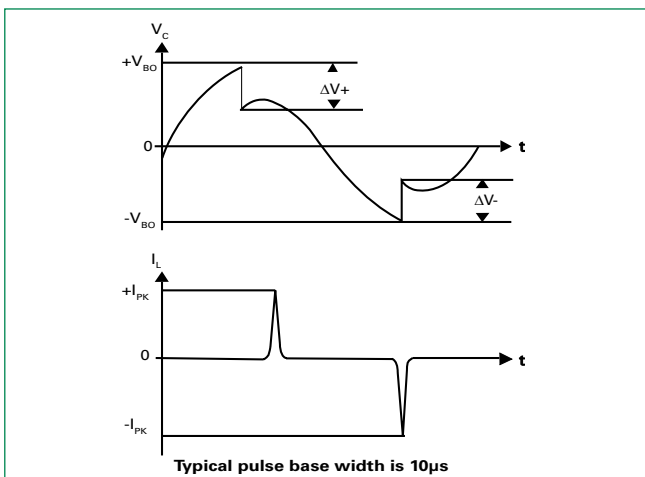
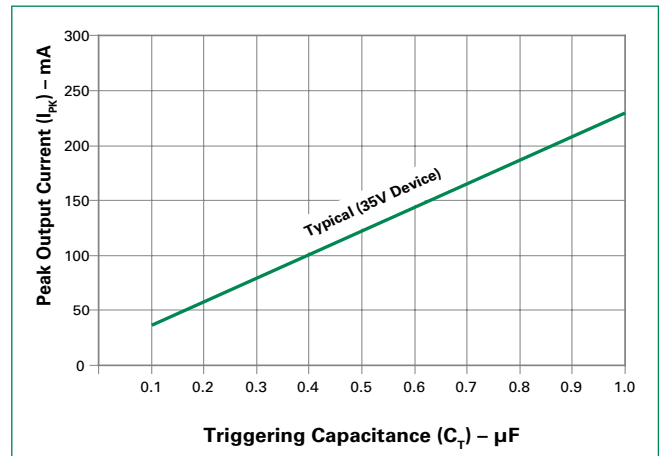
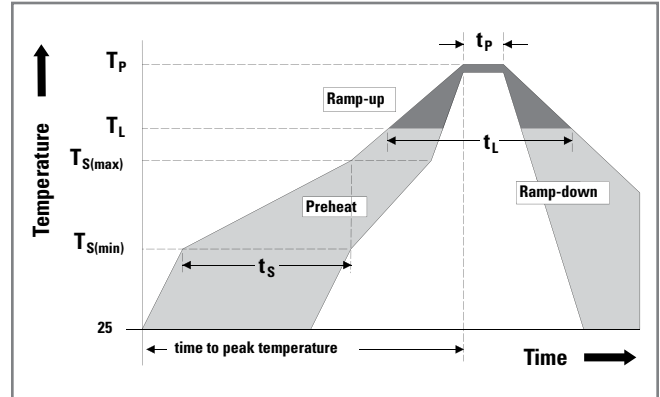

Figure 11: Peak Output Current vs Triggering Capacitance (Per Figure 9)



Soldering Parameters

Reflow Condition		Pb – Free assembly
Pre Heat	- Temperature Min ($T_{s(min)}$)	150°C
	- Temperature Max ($T_{s(max)}$)	200°C
	- Time (min to max) (t_s)	60 – 180 secs
Average ramp up rate (Liquidus Temp (T_L) to peak)		5°C/second max
$T_{s(max)}$ to T_L - Ramp-up Rate		5°C/second max
Reflow	- Temperature (T_L) (Liquidus)	217°C
	- Time (t_L)	60 – 150 seconds
Peak Temperature (T_p)		260 ^{+0/-5} °C
Time within 5°C of actual peak Temperature (t_p)		20 – 40 seconds
Ramp-down Rate		5°C/second max
Time 25°C to peak Temperature (T_p)		8 minutes Max.
Do not exceed		280°C



Physical Specifications

Terminal Finish	1005 Matte Tin-plated
Body Material	UL Recognized compound meeting flammability rating V-0
Lead Material	Copper Alloy

Design Considerations

Careful selection of the correct component for the application's operating parameters and environment will go a long way toward extending the operating life of the Thyristor. Good design practice should limit the maximum continuous current through the main terminals to 75% of the component rating. Other ways to ensure long life for a power discrete semiconductor are proper heat sinking and selection of voltage ratings for worst case conditions. Overheating, overvoltage (including dv/dt), and surge currents are the main killers of semiconductors. Correct mounting, soldering, and forming of the leads also help protect against component damage.

Environmental Specifications

Test	Specifications and Conditions
High Temperature Voltage Blocking	MIL-STD-750: Method 1040, Condition A Rated V_{DRM} (VAC-peak), 125°C, 1008 hours
Temperature Cycling	MIL-STD-750: Method 1051 -40°C to 150°C, 15-minute dwell, 1000 cycles
Biased Temperature & Humidity	EIA/JEDEC: JESD22-A101 320VDC, 85°C, 85%RH, 1008 hours
High Temp Storage	MIL-STD-750: Method 1031 150°C, 1008 hours
Low-Temp Storage	-40°C, 1008 hours
Thermal Shock	MIL-STD-750: Method 1056 0°C to 100°C, 5-minute dwell, 10-second transfer, 10 cycles
Autoclave (Pressure Cooker Test)	EIA/JEDEC: JESD22-A102 121°C, 100%RH, 2atm, 168 hours
Resistance to Solder Heat	MIL-STD-750: Method 2031 260°C, 10 seconds
Solderability	ANSI/J-STD-002, Category 3, Test A
Lead Bend	MIL-STD-750: Method 2036, Condition E

Dimensions — TO-220AB (L-Package) — Isolated Mounting Tab

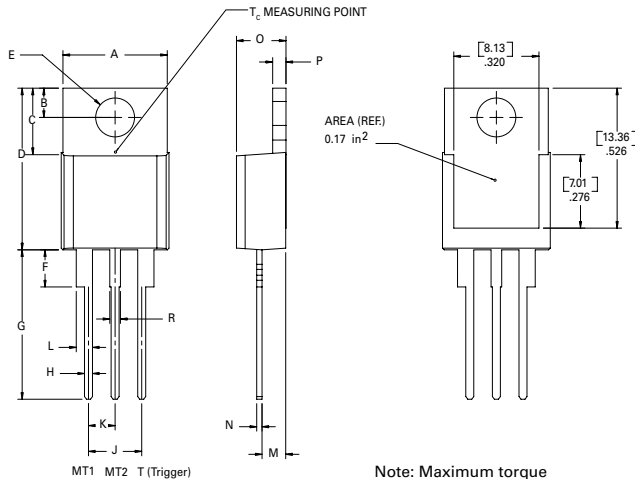

Dimension	Inches		Millimeters	
	Min	Max	Min	Max
A	0.380	0.420	9.65	10.67
B	0.105	0.115	2.67	2.92
C	0.230	0.250	5.84	6.35
D	0.590	0.620	14.99	15.75
E	0.142	0.147	3.61	3.73
F	0.110	0.130	2.79	3.30
G	0.540	0.575	13.72	14.61
H	0.025	0.035	0.64	0.89
J	0.195	0.205	4.95	5.21
K	0.095	0.105	2.41	2.67
L	0.060	0.075	1.52	1.91
M	0.085	0.095	2.16	2.41
N	0.018	0.024	0.46	0.61
O	0.178	0.188	4.52	4.78
P	0.045	0.060	1.14	1.52
R	0.038	0.048	0.97	1.22

Product Selector

Part Number	Voltage				Type	Package
	400V	600V	800V	1000V		
Qxx04LT	X	X			Quadrac	TO-220L
Qxx06LT	X	X			Quadrac	TO-220L
Qxx06LTH	X	X			Alternistor Quadrac	TO-220L
Qxx08LT	X	X			Quadrac	TO-220L
Qxx08LTH	X	X			Alternistor Quadrac	TO-220L
Qxx10LT	X	X			Quadrac	TO-220L
Qxx10LTH	X	X			Alternistor Quadrac	TO-220L
Qxx15LT	X	X			Quadrac	TO-220L
Qxx15LTH	X	X			Alternistor Quadrac	TO-220L

Note: xx = Voltage

Packing Options

Part Number	Marking	Weight	Packing Mode	Base Quantity
Qxx04LTTP	Qxx04LT	2.2 g	Tube Pack	1000 (50 per tube)
Qxx06LTTP	Qxx06LT	2.2 g	Tube Pack	1000 (50 per tube)
Qxx06LTHTP	Qxx06LTH	2.2 g	Tube Pack	1000 (50 per tube)
Qxx08LTTP	Qxx08LT	2.2 g	Tube Pack	1000 (50 per tube)
Qxx08LTHTP	Qxx08LTH	2.2 g	Tube Pack	1000 (50 per tube)
Qxx10LTTP	Qxx10LT	2.2 g	Tube Pack	1000 (50 per tube)
Qxx10LTHTP	Qxx10LTH	2.2 g	Tube Pack	1000 (50 per tube)
Qxx15LTTP	Qxx15LT	2.2 g	Tube Pack	1000 (50 per tube)
Qxx15LTHTP	Qxx15LTH	2.2 g	Tube Pack	1000 (50 per tube)

Note: xx = Voltage

Part Numbering System

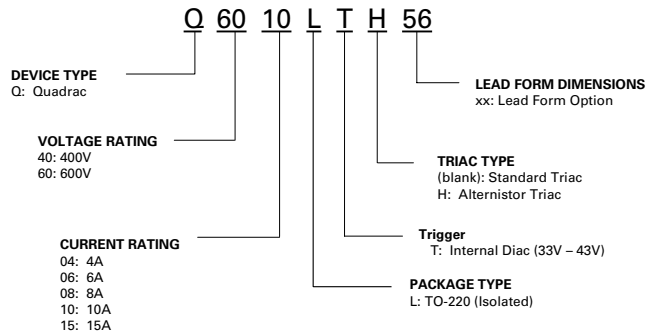

Part Marking System

TO-220 AB - (L Package)

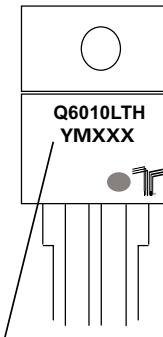

Date Code Marking
Y: Year Code
M: Month Code
XXX: Lot Trace Code



Material Composition Declaration

© Copyright 2005. IPC, Bannockburn, Illinois. All rights reserved under both international and Pan-American copyright conventions.

This document is a declaration of the substances within the manufacturer listed item. Note: if the item is an assembly with lower level parts, the declaration encompasses all lower level materials for which the manufacturer has engineering responsibility.

Adobe Reader version 7.0.5 is required to complete this declaration.

1752-2 1.1	IPC Web Site for Information on IPC-1752 Standard http://www.ipc.org/IPC-175x	Form Type * Distribute	Declaration Class * Class 6 - RoHS Yes/No, Homogeneous Materials and Mfg Informa
------------	--	---------------------------	---

Supplier Information

Company Name * Littelfuse Inc.	Company Unique ID	Unique ID Authority	Response Date * 2019-06-18	Response Document ID				
Contact Name * Lya C. Latoza	Title - Contact Global EHS Analyst	Phone - Contact * +63 430 0100	Email - Contact * EnvRequests@littelfuse.com					
Authorized Representative * Jennilyn D. Santos	Title - Representative Global EHS Supervisor	Phone - Representative * +63 430 0100	Email - Representative * EnvRequests@littelfuse.com	Supplier Comments or URL for Additional Information				
Requester Item Number	Mfr Item Number	Mfr Item Name	Effective Date	Version	Manufacturing Site	Weight *	UOM	Unit Type
Q4010LTHTP_TO220L	Q4010LTHTP_TO220L	Triac 10A TO220L	2004-01-11		China	2,206.0761607	mg	Each
Alternate Recommendation				Alternate Item Comments				

Manufacturing Process Information

Terminal Plating / Grid Array Material Matte Tin (Sn)	Terminal Base Alloy CU Alloy	J-STD-020 MSL Rating 1	Peak Process Body Temperature 260 C	Max Time at Peak Temperature 30 seconds	Number of Reflow Cycles 1
--	---------------------------------	---------------------------	--	--	------------------------------

Comments
The old exemption 5 has been replaced by Exemption 7(c)-1, Electrical and electronic components containing lead in a glass or ceramic other than dielectric ceramic in capacit

Save the fields in this form to a file

Export Data

Import fields from a file into this form

Import Data

Locked

RoHS Material Composition Declaration

Declaration Type *

Simplified

RoHS Directive 2002/95/EC **RoHS Definition:** Quantity limit of 0.1% by mass (1000 PPM) in homogeneous material for: Lead (Pb), Mercury, Hexavalent Chromium, Polybrominated Biphenyls (PBB), Polybrominated Diphenyl Ethers (PBDE) and quantity limit of 0.01% by mass (100 PPM) of homogeneous material for Cadmium

Supplier certifies that it gathered the information it provides in this form concerning RoHS restrictive substances using appropriate methods to ensure its accuracy and that such information is true and correct to the best of its knowledge and belief, as of the date that Supplier completes this form. Supplier acknowledges that Company will rely on this certification in determining the compliance of its products with European Union member state laws that implement the RoHS Directive. Company acknowledges that Supplier may have relied on information provided by others in completing this form, and that Supplier may not have independently verified such information. However, in situations where Supplier has not independently verified information provided by others, Supplier agrees that, at a minimum, its suppliers have provided certifications regarding their contributions to the part, and those certifications are at least as comprehensive as the certification in this paragraph. If the Company and the Supplier enter into a written agreement with respect to the identified part, the terms and conditions of that agreement, including any warranty rights and/or remedies provided as part of that agreement, will be the sole and exclusive source of the Supplier's liability and the Company's remedies for issues that arise regarding information the Supplier provides in this form.

RoHS Declaration * 4 - Item(s) does not contain RoHS restricted substances per the definition above except for selected exemptions

Supplier Acceptance * Accepted

Exemptions: If the declared item does not contain RoHS restricted substances per the definition above except for defined RoHS exemptions, then select the corresponding response in the RoHS Declaration above and choose all applicable exemptions.

Exemption List Version EL-2006/690/EC

5. Lead in glass of cathode ray tubes, electronic components and fluorescent tubes.

7a. Lead in high melting temperature type solders (i.e. lead based solder alloys containing 85% by weight or more lead).

Declaration Signature

Instructions: Complete all of the required fields on all pages of this form. Select the "Accepted" on the Supplier Acceptance drop-down. This will display the signature area. Digitally sign the declaration (if required by the Requester) and click on Submit Form to have the form returned to the Requester.

Supplier Digital Signature **Lya C. Latoza**

DN: cn=Lya C. Latoza, o, ou, email=llatoza@littelfuse.com,
c=PH
Date: 2019.06.18 10:18:07 +08'00'

Homogeneous Material Composition Declaration for Electronic Products

SubItem Instructions: The presence of any JIG Level A or B substances must be declared. [1] indicate the subpart in which the substance is located, [2] provide a description of the homogeneous material [3], enter the weight of the homogeneous material.

Substance Instructions: [A] select the Level (JIG A, JIG B, Requester or Supplier) [B] select the substance category (JIG or Requester) or enter a value (Supplier). [C] select the substance (JIG) or enter the substance and CAS (Other). [D] select a RoHS exemption, if applicable [E] enter the weight of the substance or the PPM concentration [F] Optionally enter the positive (+) and negative (-) tolerance in percent (Note: percent tolerance values are expected to cover a 3 sigma range of distribution unless otherwise noted).

Line Functions: +I Inserts a New Item /SubItem +M Inserts a new Material +C Inserts a new Substance Category +S Inserts a new Substance - Deletes the element line

Item/SubItem Name	Homogeneous Material	Weight	Unit of Measure	Level	Substance Category	Substance	CAS	Exempt	Weight	Unit of Measure	Tolerance		PPM
											-	+	
Triac 10A TO220L	Heatsink/Lead fr	1,570.24	mg	Supplier	CuFeP	Copper (Cu)	7440-50-8		1,567.26	mg			
						Iron (Fe)	7439-89-6		2.355370	mg			
						Phosphorus (P)	7723-14-0		0.628098	mg			
Outside Lead Fir		49.1666	mg	Supplier	Tin (Sn)	Tin (Sn)	7440-31-5		49.16666	mg			
Die attach (Solder)		2.542	mg	Supplier	(F367SN3-90M3)	Tin (Sn)	7440-31-5		0.066092	mg			
						Rosin	65997-05-9		0.15252	mg			
						Other	SYSTEM		0.061008	mg			
				A	Lead/Lead Compound	Lead	7439-92-1	7a. Lead	2.26238	mg			890,00
Die attach (Solder)		1.916	mg	Supplier	(Pb92.5Sn5Ag2.5)	Tin (Sn)	7440-31-5		0.0958	mg			
						Sliver	7440-22-4		0.0479	mg			
				A	Lead/Lead Compound	Lead	7439-92-1	7a. Lead	1.7723	mg			925,00
Chip		9.29732	mg	Supplier	Silicon (Si)	Silicon (Si)	7440-21-3		9.039642	mg			
				B	Nickel (external applic	Nickel	7440-02-0		0.257678	mg			
Chip Passivator		0.40741	mg	Supplier	SiO2	SiO2	7631-86-9		0.203705	mg			
				Supplier	PbO	PbO	1317-36-8	5. Lead in	0.181071	mg			444,43
				Supplier	Al2O3	Al2O3	1344-28-1		0.004526	mg			
				Supplier	Boron	Boron	7440-42-8		0.005613	mg			
				Supplier	Oxygen	Oxygen	7782-44-7		0.012493	mg			
Ceramic Substra		76.6666	mg	Supplier	Ceramic	Al2O3	1344-28-1		70.955	mg			
						Misc., not to declare	SYSTEM		5.711666	mg			
Molding Compou		495.833	mg	Supplier	Moulding Compound	Epoxy Cresol Novolac	29690-82-2		74.375	mg			
						Phenol Novoloac	9003-35-4		24.79166	mg			
						Metal hydroxide	SYSTEM		74.375	mg			

Carbon black	1333-86-4		4.958333	mg			
Silica Fused	60676-86-0		317.3333	mg			