



**Technical specification: 150320**  
**Specifica Tecnica:**

**Drawing Code: DT01**  
 Disegno Cod.:  
**Sheet: N° 1/1**  
 Foglio:

**Ordering code: 150320-**  
 Codice d'acquisto:

[www.sirio-ic.it](http://www.sirio-ic.it)

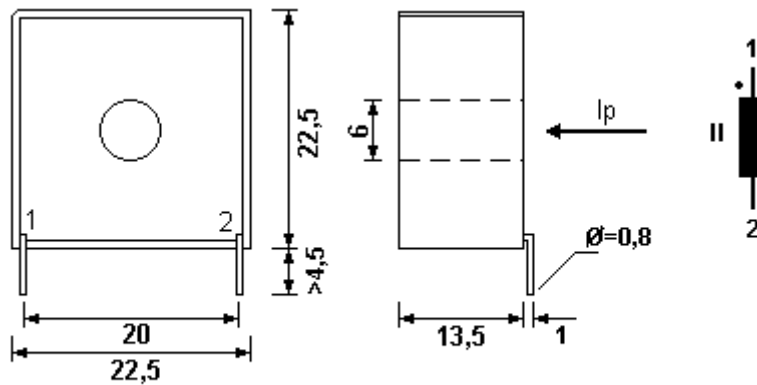

Pins side view  
 Vista lato pin

Values in mm - Misure espresse in mm

<b>Turns ratio</b>	1 : 200
Rapporto spire	
<b>Primary current</b>	25 A
Corrente primario	
<b>Secondary inductance</b>	100 mH
Induttanza secondario	
<b>Secondary winding resistance</b>	2,4 Ω
Resistenza avvolgimento secondario	
<b>Working frequency</b>	80 kHz
Frequenza di lavoro	
<b>Rated working voltage</b>	750 Vrms
Tensione di lavoro nominale	
<b>P/S insulation voltage</b>	3,5 kVrms
Tensione d'isolamento P/S	50 Hz 1'

**Final Inspections:**

Parametri Garantiti al Collaudo:

N°	Parameters Parametri	Values Valori	U.M.	Limits Limiti	Type of inspection Tipo di ispezione
1	Turns ratio Rapporto spire			O.k.	100% of pieces 100% dei pezzi
2	Polarity Polarità			O.k.	100% of pieces 100% dei pezzi

Rev.: 02 Date: 6-3-2009  
 Data

Prepared U.T. *G. Repato*

Checked C.Q. *A. Punari*

Approved Visto *M. Jirif*